

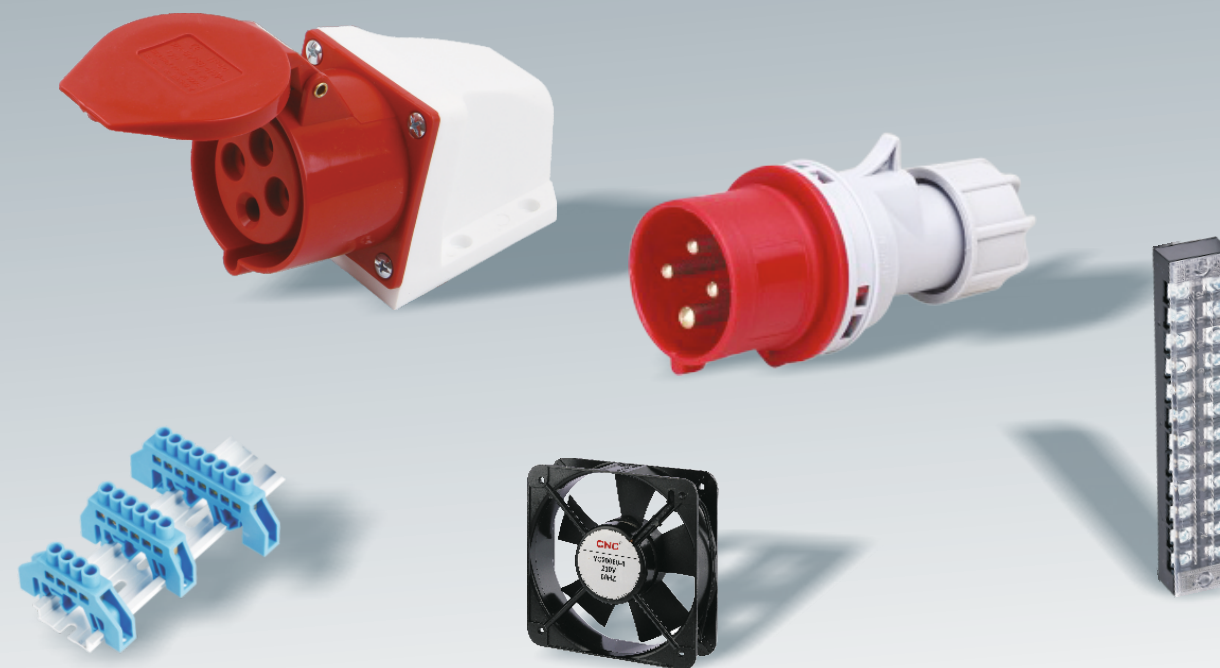

ЭЛЕКТРИЧЕСКИЕ АКСЕССУАРЫ



CNC ELECTRIC GROUP
Официальный дистрибьютор в России
125212, г. Москва, Головинское ш., 5А
+7 (499) 404 03-30
info@cncrussia.com
cncrussia.com

Данный документ предназначен исключительно для демонстрации информации о продукции CNC ELECTRIC в справочных целях. Производитель оставляет за собой право вносить изменения в данный документ в связи с техническими усовершенствованиями, внедрением новых производственных процессов, исправлением ошибок и пр. без предварительного уведомления. Пожалуйста, при размещении заказа свяжитесь с официальным дистрибьютором компании CNC ELECTRIC для подтверждения информации.

- > Промышленные розетки и вилки
- > Клеммные колодки
- > Вентиляторы
- > Концевые зажимы
- > Пластиковые аксессуары

Электрические аксессуары

Промышленные розетки и вилки



Страница H01
YHT



Страница H10
YHT-N

Соединительные клеммы



Страница H17
DTL-2



Страница H17
DT



Страница H18
SC(JGK)



Страница H18
GTL



Страница H19
GT



Страница H19
GTY

Кольцевые клеммы с изоляцией



Страница H20
RV, RVS, RVM, RVL

Кольцевые клеммы без изоляции



Страница H21
RNB, RNBS, RNBM, RNBL

Вилочный наконечник с изоляцией



Страница H23
SV, SVL, SVS, SVM

Вилочный наконечник без изоляции



Страница H24
SNB, SNBS, SNBL, SNBM

Внутренние/внешние коннекторы с изоляцией



Страница H25
FDD, MDD

Разъединители с изоляцией



Страница H26
FRD, MPD

Соединители и разъединители с изоляцией



Страница H27
BV, PVT, BNYF

Разъединители с виниловой изоляцией и разъединители с фиксатором и изоляцией



Страница H28
FDFD, FBDD

Электрические аксессуары

Штырьевые контакты с изоляцией и без изоляции



Страница H29
PTV, PTN

Плоские контакты с изоляцией и без изоляции



Страница H30
DBV

Коннекторы кабеля с изоляцией



Страница H31
E0506-E50-25

Клеммы для кабелей без изоляции и двойные клеммы



Страница H32
EN0506-EN50-20, TE0508-TE16-14

Концевой зажим



Страница H33
JXB, EK, UK, USLKG

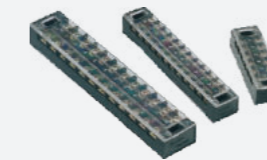

Страница H34
TB, TC

Вентиляторы



Страница H35
YC

Кабельный ввод PG



Страница H41
PG

Пластиковые аксессуары



Страница H42
Самофиксирующиеся нейлоновые кабельные стяжки

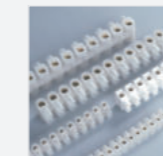

Страница H43
Клеммные колодки



Страница H44
Распределительный изолятор

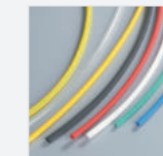

Страница H45
Огнестойкая термоусадочная трубка



Страница H46
Термоусадочная трубка с двойной стенкой

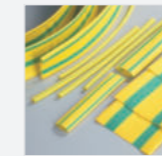

Страница H47
Желто-зеленая термоусадочная трубка



Страница H48
Спиральная лента

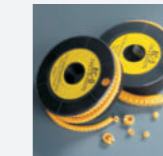

Страница H48
Маркер кабеля

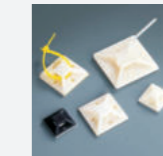

Страница H49
Крепления для стяжек

Электрические аксессуары

Клеммные колодки

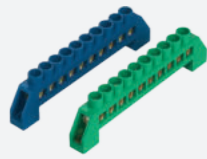

Страница H50
HC-001

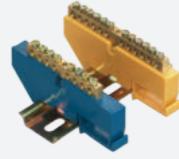

Страница H50
HC-002

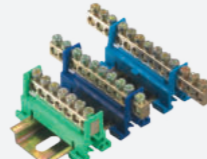

Страница H51
HC-003

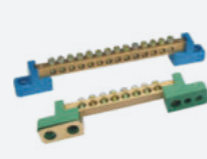

Страница H51
HC-004



Страница H52
HC-005



Страница H52
HC-006



Страница H53
HC-007



Страница H53
HC-008



Страница H54
HC-009

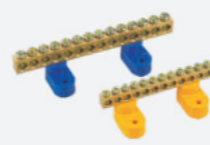

Страница H54
HL-010



Страница H55
HC-012
Клеммная колодка



Страница H55
HC-013
Клеммная колодка



Страница H56
HC-014
Клеммная колодка

HC-016

Страница H56
HC-016



207



211



407



415



215

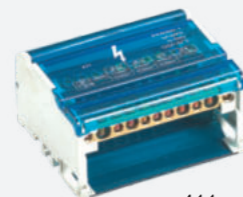

411

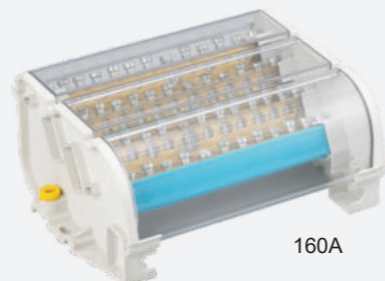

160A

Электрические аксессуары

Клеммные колодки



Страница H57
HC-017



Страница H57
HC-018



Страница H58
HC-022

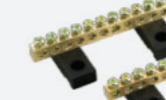

Страница H58
HC-023



Страница H58
HC-026
Клеммная колодка



Страница H59
HC-025



Страница H59
HC-024

УКК

Страница H60
УКК



УКК-80



УКК-125



УКК-160



УКК-250



УКК-400

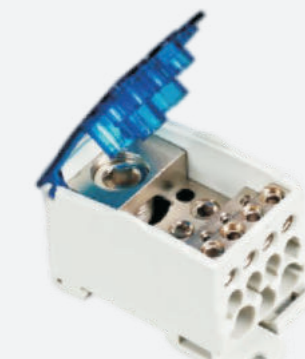

УКК-500



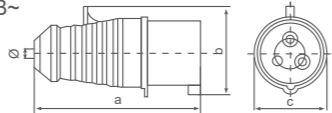
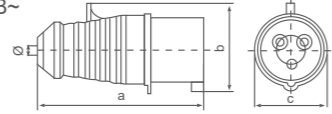
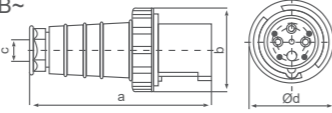
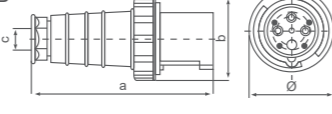



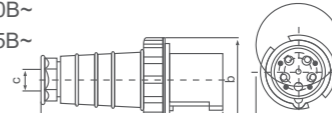
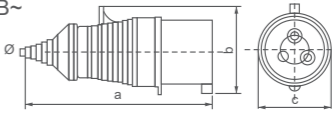
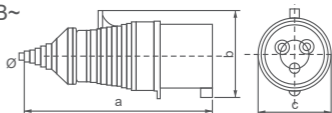
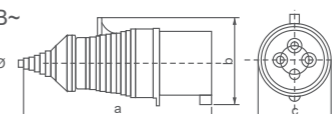
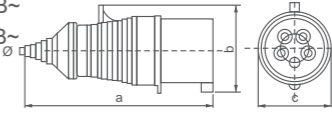
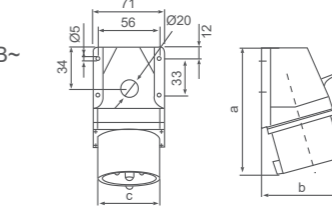



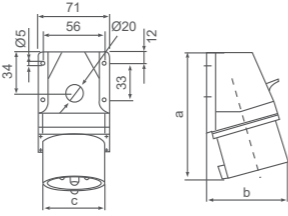

Промышленные розетки и вилки УНТ

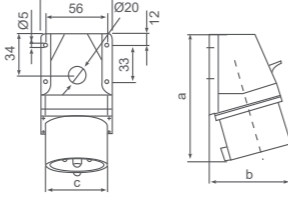
	<p>УНТ-013-4 УНТ-023-4</p> <p>Напряжение (В): 110-130В~ Ток (А): 16А, 32А Класс защиты: IP44</p> 	<table border="1"> <tr><td>Пол. контакта заземл.</td><td colspan="2">4 ч</td></tr> <tr><td>Номинальный ток (А)</td><td>16</td><td>32</td></tr> <tr><td>Полюсы</td><td colspan="2">3</td></tr> <tr><td rowspan="4">Размеры (мм)</td><td>a</td><td>122</td><td>141</td></tr> <tr><td>b</td><td>57</td><td>77</td></tr> <tr><td>c</td><td>50</td><td>64</td></tr> <tr><td>Ø</td><td>6</td><td>8</td></tr> <tr><td>Номинальное сечение кабеля (мм²)</td><td>1-2.5</td><td>2.5-6</td></tr> </table>	Пол. контакта заземл.	4 ч		Номинальный ток (А)	16	32	Полюсы	3		Размеры (мм)	a	122	141	b	57	77	c	50	64	Ø	6	8	Номинальное сечение кабеля (мм ²)	1-2.5	2.5-6
Пол. контакта заземл.	4 ч																										
Номинальный ток (А)	16	32																									
Полюсы	3																										
Размеры (мм)	a	122	141																								
	b	57	77																								
	c	50	64																								
	Ø	6	8																								
Номинальное сечение кабеля (мм ²)	1-2.5	2.5-6																									
	<p>УНТ-013 УНТ-023</p> <p>Напряжение (В): 220-240В~ Ток (А): 16А, 32А Класс защиты: IP44</p> 	<table border="1"> <tr><td>Пол. контакта заземл.</td><td colspan="2">6 ч</td></tr> <tr><td>Номинальный ток (А)</td><td>16</td><td>32</td></tr> <tr><td>Полюсы</td><td colspan="2">3</td></tr> <tr><td rowspan="4">Размеры (мм)</td><td>a</td><td>122</td><td>141</td></tr> <tr><td>b</td><td>57</td><td>77</td></tr> <tr><td>c</td><td>50</td><td>64</td></tr> <tr><td>Ø</td><td>6</td><td>8</td></tr> <tr><td>Номинальное сечение кабеля (мм²)</td><td>1-2.5</td><td>2.5-6</td></tr> </table>	Пол. контакта заземл.	6 ч		Номинальный ток (А)	16	32	Полюсы	3		Размеры (мм)	a	122	141	b	57	77	c	50	64	Ø	6	8	Номинальное сечение кабеля (мм ²)	1-2.5	2.5-6
Пол. контакта заземл.	6 ч																										
Номинальный ток (А)	16	32																									
Полюсы	3																										
Размеры (мм)	a	122	141																								
	b	57	77																								
	c	50	64																								
	Ø	6	8																								
Номинальное сечение кабеля (мм ²)	1-2.5	2.5-6																									
	<p>УНТ-014 УНТ-024</p> <p>Напряжение (В): 380-415В~ Ток (А): 16А, 32А Класс защиты: IP44</p> 	<table border="1"> <tr><td>Пол. контакта заземл.</td><td colspan="2">6 ч</td></tr> <tr><td>Номинальный ток (А)</td><td>16</td><td>32</td></tr> <tr><td>Полюсы</td><td colspan="2">4</td></tr> <tr><td rowspan="4">Размеры (мм)</td><td>a</td><td>122</td><td>141</td></tr> <tr><td>b</td><td>57</td><td>77</td></tr> <tr><td>c</td><td>50</td><td>64</td></tr> <tr><td>Ø</td><td>6</td><td>8</td></tr> <tr><td>Номинальное сечение кабеля (мм²)</td><td>1-2.5</td><td>2.5-6</td></tr> </table>	Пол. контакта заземл.	6 ч		Номинальный ток (А)	16	32	Полюсы	4		Размеры (мм)	a	122	141	b	57	77	c	50	64	Ø	6	8	Номинальное сечение кабеля (мм ²)	1-2.5	2.5-6
Пол. контакта заземл.	6 ч																										
Номинальный ток (А)	16	32																									
Полюсы	4																										
Размеры (мм)	a	122	141																								
	b	57	77																								
	c	50	64																								
	Ø	6	8																								
Номинальное сечение кабеля (мм ²)	1-2.5	2.5-6																									
	<p>УНТ-015 УНТ-025</p> <p>Напряжение (В): 220-380В~ 240-415В~ Ток (А): 16А, 32А Класс защиты: IP44</p> 	<table border="1"> <tr><td>Пол. контакта заземл.</td><td colspan="2">6 ч</td></tr> <tr><td>Номинальный ток (А)</td><td>16</td><td>32</td></tr> <tr><td>Полюсы</td><td colspan="2">5</td></tr> <tr><td rowspan="4">Размеры (мм)</td><td>a</td><td>130</td><td>141</td></tr> <tr><td>b</td><td>75</td><td>87</td></tr> <tr><td>c</td><td>64</td><td>70</td></tr> <tr><td>Ø</td><td>8</td><td>8</td></tr> <tr><td>Номинальное сечение кабеля (мм²)</td><td>1-2.5</td><td>2.5-6</td></tr> </table>	Пол. контакта заземл.	6 ч		Номинальный ток (А)	16	32	Полюсы	5		Размеры (мм)	a	130	141	b	75	87	c	64	70	Ø	8	8	Номинальное сечение кабеля (мм ²)	1-2.5	2.5-6
Пол. контакта заземл.	6 ч																										
Номинальный ток (А)	16	32																									
Полюсы	5																										
Размеры (мм)	a	130	141																								
	b	75	87																								
	c	64	70																								
	Ø	8	8																								
Номинальное сечение кабеля (мм ²)	1-2.5	2.5-6																									
	<p>УНТ-033 УНТ-043</p> <p>Напряжение (В): 220-240В~ Ток (А): 63А, 125А Класс защиты: IP67</p> 	<table border="1"> <tr><td>Пол. контакта заземл.</td><td colspan="2">6 ч</td></tr> <tr><td>Номинальный ток (А)</td><td>63</td><td>125</td></tr> <tr><td>Полюсы</td><td colspan="2">3</td></tr> <tr><td rowspan="4">Размеры (мм)</td><td>a</td><td>231.5</td><td>295</td></tr> <tr><td>b</td><td>110</td><td>123</td></tr> <tr><td>c</td><td>16-38</td><td>30-64</td></tr> <tr><td>Ø</td><td>110</td><td>123</td></tr> <tr><td>Номинальное сечение кабеля (мм²)</td><td>6-16</td><td>16-50</td></tr> </table>	Пол. контакта заземл.	6 ч		Номинальный ток (А)	63	125	Полюсы	3		Размеры (мм)	a	231.5	295	b	110	123	c	16-38	30-64	Ø	110	123	Номинальное сечение кабеля (мм ²)	6-16	16-50
Пол. контакта заземл.	6 ч																										
Номинальный ток (А)	63	125																									
Полюсы	3																										
Размеры (мм)	a	231.5	295																								
	b	110	123																								
	c	16-38	30-64																								
	Ø	110	123																								
Номинальное сечение кабеля (мм ²)	6-16	16-50																									
	<p>УНТ-034 УНТ-044</p> <p>Напряжение (В): 380-415В~ Ток (А): 63А, 125А Класс защиты: IP67</p> 	<table border="1"> <tr><td>Пол. контакта заземл.</td><td colspan="2">6 ч</td></tr> <tr><td>Номинальный ток (А)</td><td>63</td><td>125</td></tr> <tr><td>Полюсы</td><td colspan="2">4</td></tr> <tr><td rowspan="4">Размеры (мм)</td><td>a</td><td>231.5</td><td>295</td></tr> <tr><td>b</td><td>110</td><td>123</td></tr> <tr><td>c</td><td>16-38</td><td>30-64</td></tr> <tr><td>Ø</td><td>110</td><td>123</td></tr> <tr><td>Номинальное сечение кабеля (мм²)</td><td>6-16</td><td>16-50</td></tr> </table>	Пол. контакта заземл.	6 ч		Номинальный ток (А)	63	125	Полюсы	4		Размеры (мм)	a	231.5	295	b	110	123	c	16-38	30-64	Ø	110	123	Номинальное сечение кабеля (мм ²)	6-16	16-50
Пол. контакта заземл.	6 ч																										
Номинальный ток (А)	63	125																									
Полюсы	4																										
Размеры (мм)	a	231.5	295																								
	b	110	123																								
	c	16-38	30-64																								
	Ø	110	123																								
Номинальное сечение кабеля (мм ²)	6-16	16-50																									

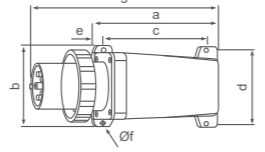

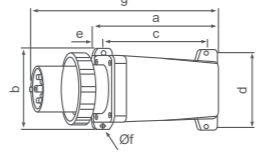

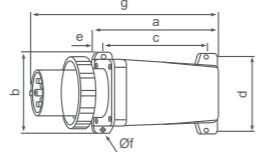

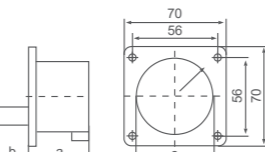



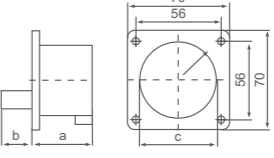

Промышленные розетки и вилки УНТ

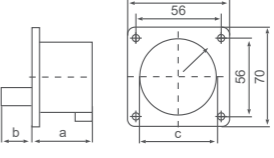
	<p>УНТ-035 УНТ-045</p> <p>Напряжение (В): 220-380В~ 240-415В~ Ток (А): 63А, 125А Класс защиты: IP67</p> 	<table border="1"> <tr><td>Пол. контакта заземл.</td><td colspan="2">6 ч</td></tr> <tr><td>Номинальный ток (А)</td><td>63</td><td>125</td></tr> <tr><td>Полюсы</td><td colspan="2">5</td></tr> <tr><td rowspan="4">Размеры (мм)</td><td>a</td><td>231.5</td><td>295</td></tr> <tr><td>b</td><td>110</td><td>123</td></tr> <tr><td>c</td><td>16-38</td><td>30-64</td></tr> <tr><td>Ø</td><td>110</td><td>123</td></tr> <tr><td>Номинальное сечение кабеля (мм²)</td><td>6-16</td><td>16-50</td></tr> </table>	Пол. контакта заземл.	6 ч		Номинальный ток (А)	63	125	Полюсы	5		Размеры (мм)	a	231.5	295	b	110	123	c	16-38	30-64	Ø	110	123	Номинальное сечение кабеля (мм ²)	6-16	16-50
Пол. контакта заземл.	6 ч																										
Номинальный ток (А)	63	125																									
Полюсы	5																										
Размеры (мм)	a	231.5	295																								
	b	110	123																								
	c	16-38	30-64																								
	Ø	110	123																								
Номинальное сечение кабеля (мм ²)	6-16	16-50																									
	<p>УНТ-013L-4 УНТ-023L-4</p> <p>Напряжение(В): 110-130В~ Ток (А): 16А, 32А Класс защиты: IP44</p> 	<table border="1"> <tr><td>Пол. контакта заземл.</td><td colspan="2">4 ч</td></tr> <tr><td>Номинальный ток (А)</td><td>16</td><td>32</td></tr> <tr><td>Полюсы</td><td colspan="2">3</td></tr> <tr><td rowspan="4">Размеры (мм)</td><td>a</td><td>142</td><td>171</td></tr> <tr><td>b</td><td>57</td><td>77</td></tr> <tr><td>c</td><td>50</td><td>64</td></tr> <tr><td>Ø</td><td>7-16</td><td>7-20</td></tr> <tr><td>Номинальное сечение кабеля (мм²)</td><td>1-2.5</td><td>2.5-6</td></tr> </table>	Пол. контакта заземл.	4 ч		Номинальный ток (А)	16	32	Полюсы	3		Размеры (мм)	a	142	171	b	57	77	c	50	64	Ø	7-16	7-20	Номинальное сечение кабеля (мм ²)	1-2.5	2.5-6
Пол. контакта заземл.	4 ч																										
Номинальный ток (А)	16	32																									
Полюсы	3																										
Размеры (мм)	a	142	171																								
	b	57	77																								
	c	50	64																								
	Ø	7-16	7-20																								
Номинальное сечение кабеля (мм ²)	1-2.5	2.5-6																									
	<p>УНТ-013L УНТ-023L</p> <p>Напряжение(В): 220-240В~ Ток (А): 16А, 32А Класс защиты: IP44</p> 	<table border="1"> <tr><td>Пол. контакта заземл.</td><td colspan="2">6 ч</td></tr> <tr><td>Номинальный ток (А)</td><td>16</td><td>32</td></tr> <tr><td>Полюсы</td><td colspan="2">3</td></tr> <tr><td rowspan="4">Размеры (мм)</td><td>a</td><td>142</td><td>171</td></tr> <tr><td>b</td><td>57</td><td>77</td></tr> <tr><td>c</td><td>50</td><td>64</td></tr> <tr><td>Ø</td><td>7-16</td><td>7-20</td></tr> <tr><td>Номинальное сечение кабеля (мм²)</td><td>1-2.5</td><td>2.5-6</td></tr> </table>	Пол. контакта заземл.	6 ч		Номинальный ток (А)	16	32	Полюсы	3		Размеры (мм)	a	142	171	b	57	77	c	50	64	Ø	7-16	7-20	Номинальное сечение кабеля (мм ²)	1-2.5	2.5-6
Пол. контакта заземл.	6 ч																										
Номинальный ток (А)	16	32																									
Полюсы	3																										
Размеры (мм)	a	142	171																								
	b	57	77																								
	c	50	64																								
	Ø	7-16	7-20																								
Номинальное сечение кабеля (мм ²)	1-2.5	2.5-6																									
	<p>УНТ-014L УНТ-024L</p> <p>Напряжение(В): 380-415В~ Ток (А): 16А, 32А Класс защиты: IP44</p> 	<table border="1"> <tr><td>Пол. контакта заземл.</td><td colspan="2">6 ч</td></tr> <tr><td>Номинальный ток (А)</td><td>16</td><td>32</td></tr> <tr><td>Полюсы</td><td colspan="2">4</td></tr> <tr><td rowspan="4">Размеры (мм)</td><td>a</td><td>142</td><td>171</td></tr> <tr><td>b</td><td>57</td><td>77</td></tr> <tr><td>c</td><td>50</td><td>64</td></tr> <tr><td>Ø</td><td>7-16</td><td>7-20</td></tr> <tr><td>Номинальное сечение кабеля (мм²)</td><td>1-2.5</td><td>2.5-6</td></tr> </table>	Пол. контакта заземл.	6 ч		Номинальный ток (А)	16	32	Полюсы	4		Размеры (мм)	a	142	171	b	57	77	c	50	64	Ø	7-16	7-20	Номинальное сечение кабеля (мм ²)	1-2.5	2.5-6
Пол. контакта заземл.	6 ч																										
Номинальный ток (А)	16	32																									
Полюсы	4																										
Размеры (мм)	a	142	171																								
	b	57	77																								
	c	50	64																								
	Ø	7-16	7-20																								
Номинальное сечение кабеля (мм ²)	1-2.5	2.5-6																									
	<p>УНТ-015L УНТ-025L</p> <p>Напряжение(В): 220-380В~ 240-415В~ Ток (А): 16А, 32А Класс защиты: IP44</p> 	<table border="1"> <tr><td>Пол. контакта заземл.</td><td colspan="2">6 ч</td></tr> <tr><td>Номинальный ток (А)</td><td>16</td><td>32</td></tr> <tr><td>Полюсы</td><td colspan="2">5</td></tr> <tr><td rowspan="4">Размеры (мм)</td><td>a</td><td>161</td><td>174</td></tr> <tr><td>b</td><td>75</td><td>87</td></tr> <tr><td>c</td><td>64</td><td>70</td></tr> <tr><td>Ø</td><td>7-20</td><td>7-20</td></tr> <tr><td>Номинальное сечение кабеля (мм²)</td><td>1-2.5</td><td>2.5-6</td></tr> </table>	Пол. контакта заземл.	6 ч		Номинальный ток (А)	16	32	Полюсы	5		Размеры (мм)	a	161	174	b	75	87	c	64	70	Ø	7-20	7-20	Номинальное сечение кабеля (мм ²)	1-2.5	2.5-6
Пол. контакта заземл.	6 ч																										
Номинальный ток (А)	16	32																									
Полюсы	5																										
Размеры (мм)	a	161	174																								
	b	75	87																								
	c	64	70																								
	Ø	7-20	7-20																								
Номинальное сечение кабеля (мм ²)	1-2.5	2.5-6																									
	<p>УНТ-513 УНТ-523</p> <p>Напряжение(В): 220-240В~ Ток(А): 16А, 32А Класс защиты: IP44</p> 	<table border="1"> <tr><td>Пол. контакта заземл.</td><td colspan="2">6 ч</td></tr> <tr><td>Номинальный ток (А)</td><td>16</td><td>32</td></tr> <tr><td>Полюсы</td><td colspan="2">4</td></tr> <tr><td rowspan="4">Размеры (мм)</td><td>a</td><td>125</td><td>139</td></tr> <tr><td>b</td><td>70</td><td>81</td></tr> <tr><td>c</td><td>43</td><td>58</td></tr> <tr><td>Ø</td><td>3-18</td><td>3-18</td></tr> <tr><td>Номинальное сечение кабеля (мм²)</td><td>1-2.5</td><td>2.5-6</td></tr> </table>	Пол. контакта заземл.	6 ч		Номинальный ток (А)	16	32	Полюсы	4		Размеры (мм)	a	125	139	b	70	81	c	43	58	Ø	3-18	3-18	Номинальное сечение кабеля (мм ²)	1-2.5	2.5-6
Пол. контакта заземл.	6 ч																										
Номинальный ток (А)	16	32																									
Полюсы	4																										
Размеры (мм)	a	125	139																								
	b	70	81																								
	c	43	58																								
	Ø	3-18	3-18																								
Номинальное сечение кабеля (мм ²)	1-2.5	2.5-6																									

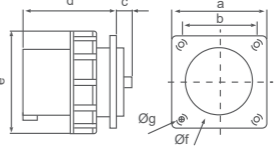

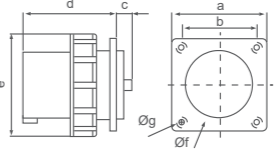

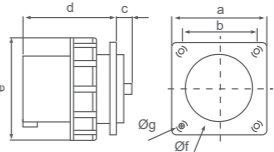

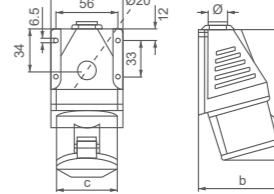



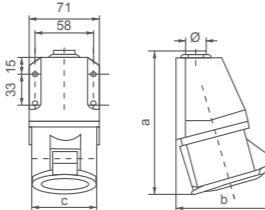

Промышленные розетки и вилки УНТ

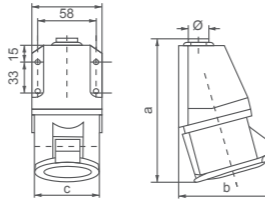
	<p>УНТ-514 УНТ-524 Напряжение(В): 380-415В~ Ток (А): 16А, 32А Класс защиты: IP44</p> 		<table border="1"> <tr><td colspan="2">Пол. контакта заземл.</td><td colspan="2">6 ч</td></tr> <tr><td colspan="2">Номинальный ток (А)</td><td>16</td><td>32</td></tr> <tr><td colspan="2">Полюсы</td><td colspan="2">4</td></tr> <tr><td rowspan="4">Размеры (мм)</td><td>a</td><td>130</td><td>139</td></tr> <tr><td>b</td><td>72</td><td>81</td></tr> <tr><td>c</td><td>49,5</td><td>58</td></tr> <tr><td>Ø</td><td>3-13</td><td>3-18</td></tr> <tr><td colspan="2">Номинальное сечение кабеля (мм²)</td><td>1-2,5</td><td>2,5-6</td></tr> </table>	Пол. контакта заземл.		6 ч		Номинальный ток (А)		16	32	Полюсы		4		Размеры (мм)	a	130	139	b	72	81	c	49,5	58	Ø	3-13	3-18	Номинальное сечение кабеля (мм ²)		1-2,5	2,5-6												
Пол. контакта заземл.		6 ч																																										
Номинальный ток (А)		16	32																																									
Полюсы		4																																										
Размеры (мм)	a	130	139																																									
	b	72	81																																									
	c	49,5	58																																									
	Ø	3-13	3-18																																									
Номинальное сечение кабеля (мм ²)		1-2,5	2,5-6																																									
	<p>УНТ-515 УНТ-525 Напряжение (В): 220-380В~ 240-415В~ Ток (А): 16А, 32А Класс защиты: IP44</p> 		<table border="1"> <tr><td colspan="2">Пол. контакта заземл.</td><td colspan="2">6 ч</td></tr> <tr><td colspan="2">Номинальный ток (А)</td><td>16</td><td>32</td></tr> <tr><td colspan="2">Полюсы</td><td colspan="2">5</td></tr> <tr><td rowspan="4">Размеры (мм)</td><td>a</td><td>130</td><td>143</td></tr> <tr><td>b</td><td>77</td><td>83</td></tr> <tr><td>c</td><td>55,5</td><td>63</td></tr> <tr><td>Ø</td><td>3-18</td><td>3-18</td></tr> <tr><td colspan="2">Номинальное сечение кабеля (мм²)</td><td>1-2,5</td><td>2,5-6</td></tr> </table>	Пол. контакта заземл.		6 ч		Номинальный ток (А)		16	32	Полюсы		5		Размеры (мм)	a	130	143	b	77	83	c	55,5	63	Ø	3-18	3-18	Номинальное сечение кабеля (мм ²)		1-2,5	2,5-6												
Пол. контакта заземл.		6 ч																																										
Номинальный ток (А)		16	32																																									
Полюсы		5																																										
Размеры (мм)	a	130	143																																									
	b	77	83																																									
	c	55,5	63																																									
	Ø	3-18	3-18																																									
Номинальное сечение кабеля (мм ²)		1-2,5	2,5-6																																									
	<p>УНТ-533 УНТ-543 Напряжение (В): 220-240В~ Ток (А): 63А, 125А Класс защиты: IP67</p> 		<table border="1"> <tr><td colspan="2">Пол. контакта заземл.</td><td colspan="2">6 ч</td></tr> <tr><td colspan="2">Номинальный ток (А)</td><td>63</td><td>125</td></tr> <tr><td colspan="2">Полюсы</td><td colspan="2">3</td></tr> <tr><td rowspan="9">Размеры (мм)</td><td>a</td><td>193</td><td>220</td></tr> <tr><td>b</td><td>122</td><td>140</td></tr> <tr><td>c</td><td>157</td><td>185</td></tr> <tr><td>d</td><td>109</td><td>130</td></tr> <tr><td>e</td><td>19</td><td>17</td></tr> <tr><td>f</td><td>6</td><td>8</td></tr> <tr><td>g</td><td>288</td><td>330</td></tr> <tr><td>h</td><td>127</td><td>140</td></tr> <tr><td colspan="2">Номинальное сечение кабеля (мм²)</td><td>6-16</td><td>16-50</td></tr> </table>	Пол. контакта заземл.		6 ч		Номинальный ток (А)		63	125	Полюсы		3		Размеры (мм)	a	193	220	b	122	140	c	157	185	d	109	130	e	19	17	f	6	8	g	288	330	h	127	140	Номинальное сечение кабеля (мм ²)		6-16	16-50
Пол. контакта заземл.		6 ч																																										
Номинальный ток (А)		63	125																																									
Полюсы		3																																										
Размеры (мм)	a	193	220																																									
	b	122	140																																									
	c	157	185																																									
	d	109	130																																									
	e	19	17																																									
	f	6	8																																									
	g	288	330																																									
	h	127	140																																									
	Номинальное сечение кабеля (мм ²)		6-16	16-50																																								
	<p>УНТ-534 УНТ-544 Напряжение (В): 380-415В~ Ток (А): 63А, 125А Класс защиты: IP67</p> 		<table border="1"> <tr><td colspan="2">Пол. контакта заземл.</td><td colspan="2">6 ч</td></tr> <tr><td colspan="2">Номинальный ток (А)</td><td>63</td><td>125</td></tr> <tr><td colspan="2">Полюсы</td><td colspan="2">4</td></tr> <tr><td rowspan="9">Размеры (мм)</td><td>a</td><td>193</td><td>220</td></tr> <tr><td>b</td><td>122</td><td>140</td></tr> <tr><td>c</td><td>157</td><td>185</td></tr> <tr><td>d</td><td>109</td><td>130</td></tr> <tr><td>e</td><td>19</td><td>17</td></tr> <tr><td>f</td><td>6</td><td>8</td></tr> <tr><td>g</td><td>288</td><td>330</td></tr> <tr><td>h</td><td>127</td><td>140</td></tr> <tr><td colspan="2">Номинальное сечение кабеля (мм²)</td><td>6-16</td><td>16-50</td></tr> </table>	Пол. контакта заземл.		6 ч		Номинальный ток (А)		63	125	Полюсы		4		Размеры (мм)	a	193	220	b	122	140	c	157	185	d	109	130	e	19	17	f	6	8	g	288	330	h	127	140	Номинальное сечение кабеля (мм ²)		6-16	16-50
Пол. контакта заземл.		6 ч																																										
Номинальный ток (А)		63	125																																									
Полюсы		4																																										
Размеры (мм)	a	193	220																																									
	b	122	140																																									
	c	157	185																																									
	d	109	130																																									
	e	19	17																																									
	f	6	8																																									
	g	288	330																																									
	h	127	140																																									
	Номинальное сечение кабеля (мм ²)		6-16	16-50																																								
	<p>УНТ-535 УНТ-545 Напряжение (В): 220-380В~ 240-415В~ Ток (А): 63А, 125А Класс защиты: IP67</p> 		<table border="1"> <tr><td colspan="2">Пол. контакта заземл.</td><td colspan="2">6 ч</td></tr> <tr><td colspan="2">Номинальный ток (А)</td><td>63</td><td>125</td></tr> <tr><td colspan="2">Полюсы</td><td colspan="2">5</td></tr> <tr><td rowspan="9">Размеры (мм)</td><td>a</td><td>193</td><td>220</td></tr> <tr><td>b</td><td>122</td><td>140</td></tr> <tr><td>c</td><td>157</td><td>185</td></tr> <tr><td>d</td><td>109</td><td>130</td></tr> <tr><td>e</td><td>19</td><td>17</td></tr> <tr><td>f</td><td>6</td><td>8</td></tr> <tr><td>g</td><td>288</td><td>330</td></tr> <tr><td>h</td><td>127</td><td>140</td></tr> <tr><td colspan="2">Номинальное сечение кабеля (мм²)</td><td>6-16</td><td>16-50</td></tr> </table>	Пол. контакта заземл.		6 ч		Номинальный ток (А)		63	125	Полюсы		5		Размеры (мм)	a	193	220	b	122	140	c	157	185	d	109	130	e	19	17	f	6	8	g	288	330	h	127	140	Номинальное сечение кабеля (мм ²)		6-16	16-50
Пол. контакта заземл.		6 ч																																										
Номинальный ток (А)		63	125																																									
Полюсы		5																																										
Размеры (мм)	a	193	220																																									
	b	122	140																																									
	c	157	185																																									
	d	109	130																																									
	e	19	17																																									
	f	6	8																																									
	g	288	330																																									
	h	127	140																																									
	Номинальное сечение кабеля (мм ²)		6-16	16-50																																								
	<p>УНТ-613 УНТ-623 Напряжение (В): 220-240В~ Ток (А): 16А, 32А Класс защиты: IP44</p> 		<table border="1"> <tr><td colspan="2">Пол. контакта заземл.</td><td colspan="2">6 ч</td></tr> <tr><td colspan="2">Номинальный ток (А)</td><td>16</td><td>32</td></tr> <tr><td colspan="2">Полюсы</td><td colspan="2">3</td></tr> <tr><td rowspan="3">Размеры (мм)</td><td>a</td><td>42</td><td>50</td></tr> <tr><td>b</td><td>25</td><td>32</td></tr> <tr><td>c</td><td>45</td><td>50</td></tr> <tr><td colspan="2">Номинальное сечение кабеля (мм²)</td><td>1-2,5</td><td>2,5-6</td></tr> </table>	Пол. контакта заземл.		6 ч		Номинальный ток (А)		16	32	Полюсы		3		Размеры (мм)	a	42	50	b	25	32	c	45	50	Номинальное сечение кабеля (мм ²)		1-2,5	2,5-6															
Пол. контакта заземл.		6 ч																																										
Номинальный ток (А)		16	32																																									
Полюсы		3																																										
Размеры (мм)	a	42	50																																									
	b	25	32																																									
	c	45	50																																									
Номинальное сечение кабеля (мм ²)		1-2,5	2,5-6																																									

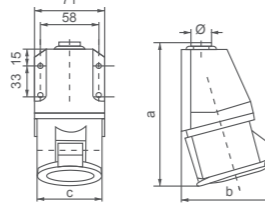

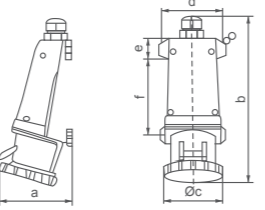

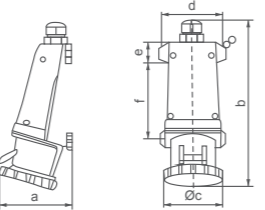

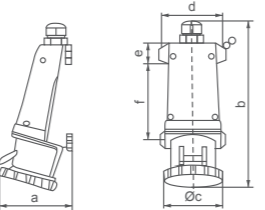



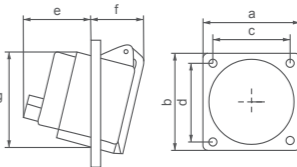

Промышленные розетки и вилки УНТ

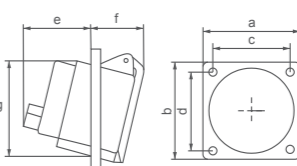
	<p>УНТ-614 УНТ-624 Напряжение (В): 380-415В~ Ток (А): 16А, 32А Класс защиты: IP44</p> 		<table border="1"> <tr><td colspan="2">Пол. контакта заземл.</td><td colspan="2">6 ч</td></tr> <tr><td colspan="2">Номинальный ток (А)</td><td>16</td><td>32</td></tr> <tr><td colspan="2">Полюсы</td><td colspan="2">4</td></tr> <tr><td rowspan="3">Размеры (мм)</td><td>a</td><td>44</td><td>50</td></tr> <tr><td>b</td><td>23</td><td>32</td></tr> <tr><td>c</td><td>45</td><td>50</td></tr> <tr><td colspan="2">Номинальное сечение кабеля (мм²)</td><td>1-2,5</td><td>2,5-6</td></tr> </table>	Пол. контакта заземл.		6 ч		Номинальный ток (А)		16	32	Полюсы		4		Размеры (мм)	a	44	50	b	23	32	c	45	50	Номинальное сечение кабеля (мм ²)		1-2,5	2,5-6												
Пол. контакта заземл.		6 ч																																							
Номинальный ток (А)		16	32																																						
Полюсы		4																																							
Размеры (мм)	a	44	50																																						
	b	23	32																																						
	c	45	50																																						
Номинальное сечение кабеля (мм ²)		1-2,5	2,5-6																																						
	<p>УНТ-615 УНТ-625 Напряжение (В): 220-380В~ 240-415В~ Ток (А): 16А, 32А Класс защиты: IP44</p> 		<table border="1"> <tr><td colspan="2">Пол. контакта заземл.</td><td colspan="2">6 ч</td></tr> <tr><td colspan="2">Номинальный ток (А)</td><td>16</td><td>32</td></tr> <tr><td colspan="2">Полюсы</td><td colspan="2">5</td></tr> <tr><td rowspan="3">Размеры (мм)</td><td>a</td><td>44</td><td>50</td></tr> <tr><td>b</td><td>22</td><td>31</td></tr> <tr><td>c</td><td>55</td><td>61</td></tr> <tr><td colspan="2">Номинальное сечение кабеля (мм²)</td><td>1-2,5</td><td>2,5-6</td></tr> </table>	Пол. контакта заземл.		6 ч		Номинальный ток (А)		16	32	Полюсы		5		Размеры (мм)	a	44	50	b	22	31	c	55	61	Номинальное сечение кабеля (мм ²)		1-2,5	2,5-6												
Пол. контакта заземл.		6 ч																																							
Номинальный ток (А)		16	32																																						
Полюсы		5																																							
Размеры (мм)	a	44	50																																						
	b	22	31																																						
	c	55	61																																						
Номинальное сечение кабеля (мм ²)		1-2,5	2,5-6																																						
	<p>УНТ-633 УНТ-643 Напряжение (В): 220-240В~ Ток (А): 63А, 125А Класс защиты: IP67</p> 		<table border="1"> <tr><td colspan="2">Пол. контакта заземл.</td><td colspan="2">6 ч</td></tr> <tr><td colspan="2">Номинальный ток (А)</td><td>63</td><td>125</td></tr> <tr><td colspan="2">Полюсы</td><td colspan="2">3</td></tr> <tr><td rowspan="9">Размеры (мм)</td><td>a</td><td>100</td><td>120</td></tr> <tr><td>b</td><td>80</td><td>100</td></tr> <tr><td>c</td><td>20</td><td>22</td></tr> <tr><td>d</td><td>108</td><td>102</td></tr> <tr><td>e</td><td>109</td><td>124</td></tr> <tr><td>f</td><td>75</td><td>100</td></tr> <tr><td>g</td><td>6,5</td><td>6,5</td></tr> <tr><td colspan="2">Номинальное сечение кабеля (мм²)</td><td>6-16</td><td>16-50</td></tr> </table>	Пол. контакта заземл.		6 ч		Номинальный ток (А)		63	125	Полюсы		3		Размеры (мм)	a	100	120	b	80	100	c	20	22	d	108	102	e	109	124	f	75	100	g	6,5	6,5	Номинальное сечение кабеля (мм ²)		6-16	16-50
Пол. контакта заземл.		6 ч																																							
Номинальный ток (А)		63	125																																						
Полюсы		3																																							
Размеры (мм)	a	100	120																																						
	b	80	100																																						
	c	20	22																																						
	d	108	102																																						
	e	109	124																																						
	f	75	100																																						
	g	6,5	6,5																																						
	Номинальное сечение кабеля (мм ²)		6-16	16-50																																					
		<p>УНТ-634 УНТ-644 Напряжение (В): 380-415В~ Ток (А): 63А, 125А Класс защиты: IP67</p> 		<table border="1"> <tr><td colspan="2">Пол. контакта заземл.</td><td colspan="2">6 ч</td></tr> <tr><td colspan="2">Номинальный ток (А)</td><td>63</td><td>125</td></tr> <tr><td colspan="2">Полюсы</td><td colspan="2">4</td></tr> <tr><td rowspan="9">Размеры (мм)</td><td>a</td><td>100</td><td>120</td></tr> <tr><td>b</td><td>80</td><td>100</td></tr> <tr><td>c</td><td>20</td><td>22</td></tr> <tr><td>d</td><td>108</td><td>102</td></tr> <tr><td>e</td><td>109</td><td>124</td></tr> <tr><td>f</td><td>75</td><td>100</td></tr> <tr><td>g</td><td>6,5</td><td>6,5</td></tr> <tr><td colspan="2">Номинальное сечение кабеля (мм²)</td><td>6-16</td><td>16-50</td></tr> </table>	Пол. контакта заземл.		6 ч		Номинальный ток (А)		63	125	Полюсы		4		Размеры (мм)	a	100	120	b	80	100	c	20	22	d	108	102	e	109	124	f	75	100	g	6,5	6,5	Номинальное сечение кабеля (мм ²)		6-16
Пол. контакта заземл.		6 ч																																							
Номинальный ток (А)		63	125																																						
Полюсы		4																																							
Размеры (мм)	a	100	120																																						
	b	80	100																																						
	c	20	22																																						
	d	108	102																																						
	e	109	124																																						
	f	75	100																																						
	g	6,5	6,5																																						
	Номинальное сечение кабеля (мм ²)		6-16	16-50																																					
		<p>УНТ-635 УНТ-645 Напряжение (В): 220-380В~ 240-415В~ Ток (А): 63А, 125А Класс защиты: IP67</p> 		<table border="1"> <tr><td colspan="2">Пол. контакта заземл.</td><td colspan="2">6 ч</td></tr> <tr><td colspan="2">Номинальный ток (А)</td><td>63</td><td>125</td></tr> <tr><td colspan="2">Полюсы</td><td colspan="2">3</td></tr> <tr><td rowspan="9">Размеры (мм)</td><td>a</td><td>100</td><td>120</td></tr> <tr><td>b</td><td>80</td><td>100</td></tr> <tr><td>c</td><td>20</td><td>22</td></tr> <tr><td>d</td><td>108</td><td>102</td></tr> <tr><td>e</td><td>109</td><td>124</td></tr> <tr><td>f</td><td>75</td><td>100</td></tr> <tr><td>g</td><td>6,5</td><td>6,5</td></tr> <tr><td colspan="2">Номинальное сечение кабеля (мм²)</td><td>6-16</td><td>16-50</td></tr> </table>	Пол. контакта заземл.		6 ч		Номинальный ток (А)		63	125	Полюсы		3		Размеры (мм)	a	100	120	b	80	100	c	20	22	d	108	102	e	109	124	f	75	100	g	6,5	6,5	Номинальное сечение кабеля (мм ²)		6-16
Пол. контакта заземл.		6 ч																																							
Номинальный ток (А)		63	125																																						
Полюсы		3																																							
Размеры (мм)	a	100	120																																						
	b	80	100																																						
	c	20	22																																						
	d	108	102																																						
	e	109	124																																						
	f	75	100																																						
	g	6,5	6,5																																						
	Номинальное сечение кабеля (мм ²)		6-16	16-50																																					
		<p>УНТ-113-4 УНТ-123-4 Напряжение (В): 110-130В~ Ток (А): 16А, 32А Класс защиты: IP44</p> 		<table border="1"> <tr><td colspan="2">Пол. контакта заземл.</td><td colspan="2">4 ч</td></tr> <tr><td colspan="2">Номинальный ток (А)</td><td>16</td><td>32</td></tr> <tr><td colspan="2">Полюсы</td><td colspan="2">3</td></tr> <tr><td rowspan="4">Размеры (мм)</td><td>a</td><td>135</td><td>153</td></tr> <tr><td>b</td><td>92</td><td>102</td></tr> <tr><td>c</td><td>50</td><td>65</td></tr> <tr><td>Ø</td><td>3-18</td><td>3-18</td></tr> <tr><td colspan="2">Номинальное сечение кабеля (мм²)</td><td>1-1,25</td><td>2,5-6</td></tr> </table>	Пол. контакта заземл.		4 ч		Номинальный ток (А)		16	32	Полюсы		3		Размеры (мм)	a	135	153	b	92	102	c	50	65	Ø	3-18	3-18	Номинальное сечение кабеля (мм ²)		1-1,25	2,5-6								
Пол. контакта заземл.		4 ч																																							
Номинальный ток (А)		16	32																																						
Полюсы		3																																							
Размеры (мм)	a	135	153																																						
	b	92	102																																						
	c	50	65																																						
	Ø	3-18	3-18																																						
Номинальное сечение кабеля (мм ²)		1-1,25	2,5-6																																						

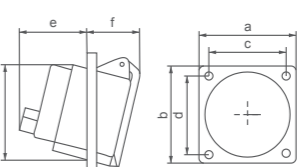

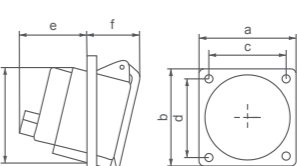

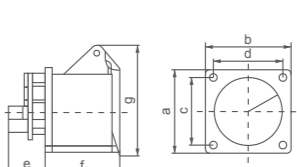

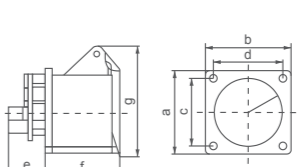

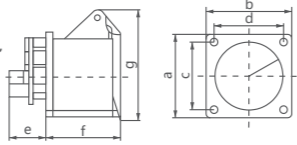

Промышленные розетки и вилки УНТ

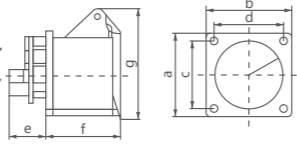
	<p>УНТ-113 УНТ-123 Ток (А): 16А, 32А Напряжение (В): 220-240В~ Класс защиты: IP44</p> 		<table border="1"> <thead> <tr> <th colspan="2">Пол. контакта заземл.</th> <th colspan="2">6 ч</th> </tr> </thead> <tbody> <tr> <td>Номинальный ток (А)</td> <td>16</td> <td>32</td> <td></td> </tr> <tr> <td>Полюсы</td> <td colspan="3">3</td> </tr> <tr> <td rowspan="4">Размеры (мм)</td> <td>a</td> <td>135</td> <td>153</td> </tr> <tr> <td>b</td> <td>92</td> <td>102</td> </tr> <tr> <td>c</td> <td>50</td> <td>65</td> </tr> <tr> <td>∅</td> <td>3-18</td> <td>3-18</td> </tr> <tr> <td>Номинальное сечение кабеля (мм²)</td> <td>1-2.5</td> <td>2.5-6</td> <td></td> </tr> </tbody> </table>	Пол. контакта заземл.		6 ч		Номинальный ток (А)	16	32		Полюсы	3			Размеры (мм)	a	135	153	b	92	102	c	50	65	∅	3-18	3-18	Номинальное сечение кабеля (мм ²)	1-2.5	2.5-6										
Пол. контакта заземл.		6 ч																																							
Номинальный ток (А)	16	32																																							
Полюсы	3																																								
Размеры (мм)	a	135	153																																						
	b	92	102																																						
	c	50	65																																						
	∅	3-18	3-18																																						
Номинальное сечение кабеля (мм ²)	1-2.5	2.5-6																																							
	<p>УНТ-114 УНТ-124 Ток (А): 16А, 32А Напряжение (В): 380-415В~ Класс защиты: IP44</p> 		<table border="1"> <thead> <tr> <th colspan="2">Пол. контакта заземл.</th> <th colspan="2">6 ч</th> </tr> </thead> <tbody> <tr> <td>Номинальный ток (А)</td> <td>16</td> <td>32</td> <td></td> </tr> <tr> <td>Полюсы</td> <td colspan="3">4</td> </tr> <tr> <td rowspan="4">Размеры (мм)</td> <td>a</td> <td>140</td> <td>152</td> </tr> <tr> <td>b</td> <td>95</td> <td>104</td> </tr> <tr> <td>c</td> <td>56</td> <td>65</td> </tr> <tr> <td>∅</td> <td>3-18</td> <td>3-18</td> </tr> <tr> <td>Номинальное сечение кабеля (мм²)</td> <td>1-2.5</td> <td>2.5-6</td> <td></td> </tr> </tbody> </table>	Пол. контакта заземл.		6 ч		Номинальный ток (А)	16	32		Полюсы	4			Размеры (мм)	a	140	152	b	95	104	c	56	65	∅	3-18	3-18	Номинальное сечение кабеля (мм ²)	1-2.5	2.5-6										
Пол. контакта заземл.		6 ч																																							
Номинальный ток (А)	16	32																																							
Полюсы	4																																								
Размеры (мм)	a	140	152																																						
	b	95	104																																						
	c	56	65																																						
	∅	3-18	3-18																																						
Номинальное сечение кабеля (мм ²)	1-2.5	2.5-6																																							
	<p>УНТ-115 УНТ-125 Ток (А): 16А, 32А Напряжение (В): 220-380В~ 240-415В~ Класс защиты: IP44</p> 		<table border="1"> <thead> <tr> <th colspan="2">Пол. контакта заземл.</th> <th colspan="2">6 ч</th> </tr> </thead> <tbody> <tr> <td>Номинальный ток (А)</td> <td>16</td> <td>32</td> <td></td> </tr> <tr> <td>Полюсы</td> <td colspan="3">5</td> </tr> <tr> <td rowspan="4">Размеры (мм)</td> <td>a</td> <td>139</td> <td>153</td> </tr> <tr> <td>b</td> <td>96</td> <td>107</td> </tr> <tr> <td>c</td> <td>63</td> <td>70</td> </tr> <tr> <td>∅</td> <td>3-18</td> <td>3-18</td> </tr> <tr> <td>Номинальное сечение кабеля (мм²)</td> <td>1-2.5</td> <td>2.5-6</td> <td></td> </tr> </tbody> </table>	Пол. контакта заземл.		6 ч		Номинальный ток (А)	16	32		Полюсы	5			Размеры (мм)	a	139	153	b	96	107	c	63	70	∅	3-18	3-18	Номинальное сечение кабеля (мм ²)	1-2.5	2.5-6										
Пол. контакта заземл.		6 ч																																							
Номинальный ток (А)	16	32																																							
Полюсы	5																																								
Размеры (мм)	a	139	153																																						
	b	96	107																																						
	c	63	70																																						
	∅	3-18	3-18																																						
Номинальное сечение кабеля (мм ²)	1-2.5	2.5-6																																							
	<p>УНТ-133 УНТ-143 Ток (А): 63А, 125А Напряжение (В): 220-240В~ Класс защиты: IP67</p> 		<table border="1"> <thead> <tr> <th colspan="2">Пол. контакта заземл.</th> <th colspan="2">6 ч</th> </tr> </thead> <tbody> <tr> <td>Номинальный ток (А)</td> <td>63</td> <td>125</td> <td></td> </tr> <tr> <td>Полюсы</td> <td colspan="3">3</td> </tr> <tr> <td rowspan="7">Размеры (мм)</td> <td>a</td> <td>134</td> <td>154</td> </tr> <tr> <td>b</td> <td>311</td> <td>338</td> </tr> <tr> <td>c</td> <td>108</td> <td>122</td> </tr> <tr> <td>d</td> <td>111</td> <td>130</td> </tr> <tr> <td>e</td> <td>20</td> <td>20</td> </tr> <tr> <td>f</td> <td>155</td> <td>187</td> </tr> <tr> <td>g</td> <td>6</td> <td>6.2</td> </tr> <tr> <td>Номинальное сечение кабеля (мм²)</td> <td>6-25</td> <td>25-70</td> <td></td> </tr> </tbody> </table>	Пол. контакта заземл.		6 ч		Номинальный ток (А)	63	125		Полюсы	3			Размеры (мм)	a	134	154	b	311	338	c	108	122	d	111	130	e	20	20	f	155	187	g	6	6.2	Номинальное сечение кабеля (мм ²)	6-25	25-70	
Пол. контакта заземл.		6 ч																																							
Номинальный ток (А)	63	125																																							
Полюсы	3																																								
Размеры (мм)	a	134	154																																						
	b	311	338																																						
	c	108	122																																						
	d	111	130																																						
	e	20	20																																						
	f	155	187																																						
	g	6	6.2																																						
Номинальное сечение кабеля (мм ²)	6-25	25-70																																							
	<p>УНТ-134 УНТ-144 Ток (А): 63А, 125А Напряжение (В): 380-415В~ Класс защиты: IP67</p> 		<table border="1"> <thead> <tr> <th colspan="2">Пол. контакта заземл.</th> <th colspan="2">6 ч</th> </tr> </thead> <tbody> <tr> <td>Номинальный ток (А)</td> <td>63</td> <td>125</td> <td></td> </tr> <tr> <td>Полюсы</td> <td colspan="3">4</td> </tr> <tr> <td rowspan="7">Размеры (мм)</td> <td>a</td> <td>134</td> <td>154</td> </tr> <tr> <td>b</td> <td>311</td> <td>338</td> </tr> <tr> <td>c</td> <td>108</td> <td>122</td> </tr> <tr> <td>d</td> <td>111</td> <td>130</td> </tr> <tr> <td>e</td> <td>20</td> <td>20</td> </tr> <tr> <td>f</td> <td>155</td> <td>187</td> </tr> <tr> <td>g</td> <td>6</td> <td>6.2</td> </tr> <tr> <td>Номинальное сечение кабеля (мм²)</td> <td>6-25</td> <td>25-70</td> <td></td> </tr> </tbody> </table>	Пол. контакта заземл.		6 ч		Номинальный ток (А)	63	125		Полюсы	4			Размеры (мм)	a	134	154	b	311	338	c	108	122	d	111	130	e	20	20	f	155	187	g	6	6.2	Номинальное сечение кабеля (мм ²)	6-25	25-70	
Пол. контакта заземл.		6 ч																																							
Номинальный ток (А)	63	125																																							
Полюсы	4																																								
Размеры (мм)	a	134	154																																						
	b	311	338																																						
	c	108	122																																						
	d	111	130																																						
	e	20	20																																						
	f	155	187																																						
	g	6	6.2																																						
Номинальное сечение кабеля (мм ²)	6-25	25-70																																							
	<p>УНТ-135 УНТ-145 Ток (А): 63А, 125А Напряжение (В): 220-380В~ 240-415В~ Класс защиты: IP67</p> 		<table border="1"> <thead> <tr> <th colspan="2">Пол. контакта заземл.</th> <th colspan="2">6 ч</th> </tr> </thead> <tbody> <tr> <td>Номинальный ток (А)</td> <td>63</td> <td>125</td> <td></td> </tr> <tr> <td>Полюсы</td> <td colspan="3">5</td> </tr> <tr> <td rowspan="7">Размеры (мм)</td> <td>a</td> <td>134</td> <td>154</td> </tr> <tr> <td>b</td> <td>311</td> <td>338</td> </tr> <tr> <td>c</td> <td>108</td> <td>122</td> </tr> <tr> <td>d</td> <td>111</td> <td>130</td> </tr> <tr> <td>e</td> <td>20</td> <td>20</td> </tr> <tr> <td>f</td> <td>155</td> <td>187</td> </tr> <tr> <td>g</td> <td>6</td> <td>6.2</td> </tr> <tr> <td>Номинальное сечение кабеля (мм²)</td> <td>6-25</td> <td>25-70</td> <td></td> </tr> </tbody> </table>	Пол. контакта заземл.		6 ч		Номинальный ток (А)	63	125		Полюсы	5			Размеры (мм)	a	134	154	b	311	338	c	108	122	d	111	130	e	20	20	f	155	187	g	6	6.2	Номинальное сечение кабеля (мм ²)	6-25	25-70	
Пол. контакта заземл.		6 ч																																							
Номинальный ток (А)	63	125																																							
Полюсы	5																																								
Размеры (мм)	a	134	154																																						
	b	311	338																																						
	c	108	122																																						
	d	111	130																																						
	e	20	20																																						
	f	155	187																																						
	g	6	6.2																																						
Номинальное сечение кабеля (мм ²)	6-25	25-70																																							

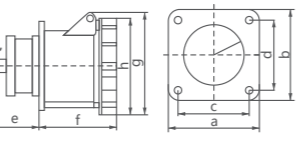

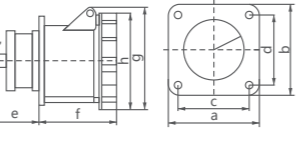

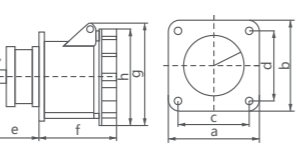

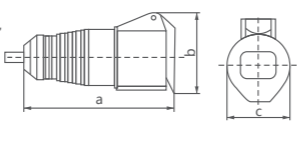

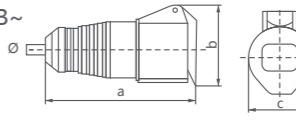

Промышленные розетки и вилки УНТ

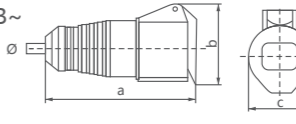
	<p>УНТ-413-4 УНТ-423-4 Ток (А): 16А, 32А Напряжение (В): 110-130В~ Класс защиты: IP44</p> 		<table border="1"> <thead> <tr> <th colspan="2">Пол. контакта заземл.</th> <th colspan="2">4 ч</th> </tr> </thead> <tbody> <tr> <td>Номинальный ток (А)</td> <td>16</td> <td>32</td> <td></td> </tr> <tr> <td>Полюсы</td> <td colspan="3">3</td> </tr> <tr> <td rowspan="7">Размеры (мм)</td> <td>a</td> <td>62</td> <td>80</td> </tr> <tr> <td>b</td> <td>68</td> <td>96</td> </tr> <tr> <td>c</td> <td>47</td> <td>60</td> </tr> <tr> <td>d</td> <td>48</td> <td>70</td> </tr> <tr> <td>e</td> <td>36</td> <td>42</td> </tr> <tr> <td>f</td> <td>37</td> <td>43</td> </tr> <tr> <td>g</td> <td>55</td> <td>75</td> </tr> <tr> <td>Номинальное сечение кабеля (мм²)</td> <td>1-2.5</td> <td>2.5-6</td> <td></td> </tr> </tbody> </table>	Пол. контакта заземл.		4 ч		Номинальный ток (А)	16	32		Полюсы	3			Размеры (мм)	a	62	80	b	68	96	c	47	60	d	48	70	e	36	42	f	37	43	g	55	75	Номинальное сечение кабеля (мм ²)	1-2.5	2.5-6							
Пол. контакта заземл.		4 ч																																													
Номинальный ток (А)	16	32																																													
Полюсы	3																																														
Размеры (мм)	a	62	80																																												
	b	68	96																																												
	c	47	60																																												
	d	48	70																																												
	e	36	42																																												
	f	37	43																																												
	g	55	75																																												
Номинальное сечение кабеля (мм ²)	1-2.5	2.5-6																																													
	<p>УНТ-413 УНТ-423 Ток (А): 16А, 32А Напряжение (В): 220-240В~ Класс защиты: IP44</p> 		<table border="1"> <thead> <tr> <th colspan="2">Пол. контакта заземл.</th> <th colspan="2">6 ч</th> </tr> </thead> <tbody> <tr> <td>Номинальный ток (А)</td> <td>16</td> <td>32</td> <td></td> </tr> <tr> <td>Полюсы</td> <td colspan="3">3</td> </tr> <tr> <td rowspan="7">Размеры (мм)</td> <td>a</td> <td>62</td> <td>80</td> </tr> <tr> <td>b</td> <td>68</td> <td>96</td> </tr> <tr> <td>c</td> <td>47</td> <td>60</td> </tr> <tr> <td>d</td> <td>48</td> <td>70</td> </tr> <tr> <td>e</td> <td>36</td> <td>42</td> </tr> <tr> <td>f</td> <td>37</td> <td>43</td> </tr> <tr> <td>g</td> <td>55</td> <td>75</td> </tr> <tr> <td>Номинальное сечение кабеля (мм²)</td> <td>1-2.5</td> <td>2.5-6</td> <td></td> </tr> </tbody> </table>	Пол. контакта заземл.		6 ч		Номинальный ток (А)	16	32		Полюсы	3			Размеры (мм)	a	62	80	b	68	96	c	47	60	d	48	70	e	36	42	f	37	43	g	55	75	Номинальное сечение кабеля (мм ²)	1-2.5	2.5-6							
Пол. контакта заземл.		6 ч																																													
Номинальный ток (А)	16	32																																													
Полюсы	3																																														
Размеры (мм)	a	62	80																																												
	b	68	96																																												
	c	47	60																																												
	d	48	70																																												
	e	36	42																																												
	f	37	43																																												
	g	55	75																																												
Номинальное сечение кабеля (мм ²)	1-2.5	2.5-6																																													
	<p>УНТ-414 УНТ-424 Ток (А): 16А, 32А Напряжение (В): 380-415В~ Класс защиты: IP44</p> 		<table border="1"> <thead> <tr> <th colspan="2">Пол. контакта заземл.</th> <th colspan="2">6 ч</th> </tr> </thead> <tbody> <tr> <td>Номинальный ток (А)</td> <td>16</td> <td>32</td> <td></td> </tr> <tr> <td>Полюсы</td> <td colspan="3">4</td> </tr> <tr> <td rowspan="7">Размеры (мм)</td> <td>a</td> <td>76</td> <td>80</td> </tr> <tr> <td>b</td> <td>86</td> <td>96</td> </tr> <tr> <td>c</td> <td>60</td> <td>60</td> </tr> <tr> <td>d</td> <td>61</td> <td>70</td> </tr> <tr> <td>e</td> <td>47</td> <td>42</td> </tr> <tr> <td>f</td> <td>37</td> <td>43</td> </tr> <tr> <td>g</td> <td>64</td> <td>75</td> </tr> <tr> <td>Номинальное сечение кабеля (мм²)</td> <td>1-2.5</td> <td>2.5-6</td> <td></td> </tr> </tbody> </table>	Пол. контакта заземл.		6 ч		Номинальный ток (А)	16	32		Полюсы	4			Размеры (мм)	a	76	80	b	86	96	c	60	60	d	61	70	e	47	42	f	37	43	g	64	75	Номинальное сечение кабеля (мм ²)	1-2.5	2.5-6							
Пол. контакта заземл.		6 ч																																													
Номинальный ток (А)	16	32																																													
Полюсы	4																																														
Размеры (мм)	a	76	80																																												
	b	86	96																																												
	c	60	60																																												
	d	61	70																																												
	e	47	42																																												
	f	37	43																																												
	g	64	75																																												
Номинальное сечение кабеля (мм ²)	1-2.5	2.5-6																																													
	<p>УНТ-415 УНТ-425 Ток (А): 16А, 32А Напряжение (В): 220-380В~ 240-415В~ Класс защиты: IP44</p> 		<table border="1"> <thead> <tr> <th colspan="2">Пол. контакта заземл.</th> <th colspan="2">6 ч</th> </tr> </thead> <tbody> <tr> <td>Номинальный ток (А)</td> <td>16</td> <td>32</td> <td></td> </tr> <tr> <td>Полюсы</td> <td colspan="3">5</td> </tr> <tr> <td rowspan="7">Размеры (мм)</td> <td>a</td> <td>76</td> <td>82</td> </tr> <tr> <td>b</td> <td>86</td> <td>97</td> </tr> <tr> <td>c</td> <td>60</td> <td>60</td> </tr> <tr> <td>d</td> <td>61</td> <td>70</td> </tr> <tr> <td>e</td> <td>47</td> <td>42</td> </tr> <tr> <td>f</td> <td>37</td> <td>47</td> </tr> <tr> <td>g</td> <td>72</td> <td>81</td> </tr> <tr> <td>Номинальное сечение кабеля (мм²)</td> <td>1-2.5</td> <td>2.5-6</td> <td></td> </tr> </tbody> </table>	Пол. контакта заземл.		6 ч		Номинальный ток (А)	16	32		Полюсы	5			Размеры (мм)	a	76	82	b	86	97	c	60	60	d	61	70	e	47	42	f	37	47	g	72	81	Номинальное сечение кабеля (мм ²)	1-2.5	2.5-6							
Пол. контакта заземл.		6 ч																																													
Номинальный ток (А)	16	32																																													
Полюсы	5																																														
Размеры (мм)	a	76	82																																												
	b	86	97																																												
	c	60	60																																												
	d	61	70																																												
	e	47	42																																												
	f	37	47																																												
	g	72	81																																												
Номинальное сечение кабеля (мм ²)	1-2.5	2.5-6																																													
	<p>УНТ-313-4 УНТ-323-4 Ток (А): 16А, 32А Напряжение (В): 110-130В~ Класс защиты: IP44</p> 		<table border="1"> <thead> <tr> <th colspan="2">Пол. контакта заземл.</th> <th colspan="2">4 ч</th> </tr> </thead> <tbody> <tr> <td>Номинальный ток (А)</td> <td>16</td> <td>32</td> <td></td> </tr> <tr> <td>Полюсы</td> <td colspan="3">3</td> </tr> <tr> <td rowspan="9">Размеры (мм)</td> <td>a</td> <td>69.5</td> <td>71</td> </tr> <tr> <td>b</td> <td>69.5</td> <td>71</td> </tr> <tr> <td>c</td> <td>56</td> <td>56</td> </tr> <tr> <td>d</td> <td>56</td> <td>56</td> </tr> <tr> <td>e</td> <td>28</td> <td>28</td> </tr> <tr> <td>f</td> <td>48</td> <td>63</td> </tr> <tr> <td>g</td> <td>70</td> <td>88</td> </tr> <tr> <td>h</td> <td>52</td> <td>56</td> </tr> <tr> <td>i</td> <td>52</td> <td>56</td> </tr> <tr> <td>Номинальное сечение кабеля (мм²)</td> <td>1-2.5</td> <td>2.5-6</td> <td></td> </tr> </tbody> </table>	Пол. контакта заземл.		4 ч		Номинальный ток (А)	16	32		Полюсы	3			Размеры (мм)	a	69.5	71	b	69.5	71	c	56	56	d	56	56	e	28	28	f	48	63	g	70	88	h	52	56	i	52	56	Номинальное сечение кабеля (мм ²)	1-2.5	2.5-6	
Пол. контакта заземл.		4 ч																																													
Номинальный ток (А)	16	32																																													
Полюсы	3																																														
Размеры (мм)	a	69.5	71																																												
	b	69.5	71																																												
	c	56	56																																												
	d	56	56																																												
	e	28	28																																												
	f	48	63																																												
	g	70	88																																												
	h	52	56																																												
	i	52	56																																												
Номинальное сечение кабеля (мм ²)	1-2.5	2.5-6																																													
	<p>УНТ-313 УНТ-323 Ток (А): 16А, 32А Напряжение (В): 220-240В~ Класс защиты: IP44</p> 		<table border="1"> <thead> <tr> <th colspan="2">Пол. контакта заземл.</th> <th colspan="2">6 ч</th> </tr> </thead> <tbody> <tr> <td>Номинальный ток (А)</td> <td>16</td> <td>32</td> <td></td> </tr> <tr> <td>Полюсы</td> <td colspan="3">3</td> </tr> <tr> <td rowspan="9">Размеры (мм)</td> <td>a</td> <td>69.5</td> <td>71</td> </tr> <tr> <td>b</td> <td>69.5</td> <td>71</td> </tr> <tr> <td>c</td> <td>56</td> <td>56</td> </tr> <tr> <td>d</td> <td>56</td> <td>56</td> </tr> <tr> <td>e</td> <td>28</td> <td>28</td> </tr> <tr> <td>f</td> <td>48</td> <td>63</td> </tr> <tr> <td>g</td> <td>70</td> <td>88</td> </tr> <tr> <td>h</td> <td>52</td> <td>56</td> </tr> <tr> <td>i</td> <td>52</td> <td>56</td> </tr> <tr> <td>Номинальное сечение кабеля (мм²)</td> <td>1-2.5</td> <td>2.5-6</td> <td></td> </tr> </tbody> </table>	Пол. контакта заземл.		6 ч		Номинальный ток (А)	16	32		Полюсы	3			Размеры (мм)	a	69.5	71	b	69.5	71	c	56	56	d	56	56	e	28	28	f	48	63	g	70	88	h	52	56	i	52	56	Номинальное сечение кабеля (мм ²)	1-2.5	2.5-6	
Пол. контакта заземл.		6 ч																																													
Номинальный ток (А)	16	32																																													
Полюсы	3																																														
Размеры (мм)	a	69.5	71																																												
	b	69.5	71																																												
	c	56	56																																												
	d	56	56																																												
	e	28	28																																												
	f	48	63																																												
	g	70	88																																												
	h	52	56																																												
	i	52	56																																												
Номинальное сечение кабеля (мм ²)	1-2.5	2.5-6																																													

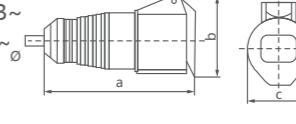

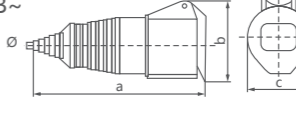

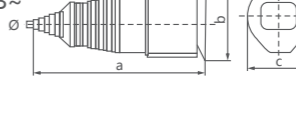

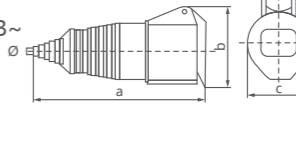
Промышленные розетки и вилки **УНТ**



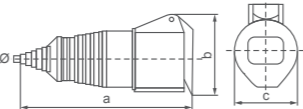

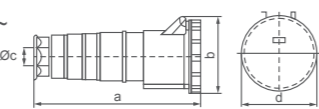

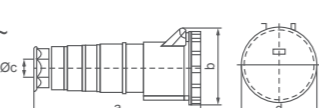
	<p>УНТ-314 УНТ-324 Ток (А): 16А, 32А Напряжение (В): 380-415В~ Класс защиты: IP44</p> 	<table border="1"> <tr><td colspan="2">Пол. контакта заземл.</td><td colspan="2">6 ч</td></tr> <tr><td colspan="2">Номинальный ток (А)</td><td>16</td><td>32</td></tr> <tr><td colspan="4">Полюсы</td></tr> <tr><td colspan="4">4</td></tr> <tr><td colspan="2">Размеры (мм)</td><td>a</td><td>b</td></tr> <tr><td colspan="2"></td><td>70</td><td>71</td></tr> <tr><td colspan="2"></td><td>70</td><td>71</td></tr> <tr><td colspan="2"></td><td>56</td><td>56</td></tr> <tr><td colspan="2"></td><td>56</td><td>56</td></tr> <tr><td colspan="2"></td><td>28</td><td>28</td></tr> <tr><td colspan="2"></td><td>51</td><td>63</td></tr> <tr><td colspan="2"></td><td>80</td><td>88</td></tr> <tr><td colspan="2"></td><td>56</td><td>56</td></tr> <tr><td colspan="2">Номинальное сечение кабеля (мм²)</td><td>1-2.5</td><td>2.5-6</td></tr> </table>	Пол. контакта заземл.		6 ч		Номинальный ток (А)		16	32	Полюсы				4				Размеры (мм)		a	b			70	71			70	71			56	56			56	56			28	28			51	63			80	88			56	56	Номинальное сечение кабеля (мм ²)		1-2.5	2.5-6				
Пол. контакта заземл.		6 ч																																																												
Номинальный ток (А)		16	32																																																											
Полюсы																																																														
4																																																														
Размеры (мм)		a	b																																																											
		70	71																																																											
		70	71																																																											
		56	56																																																											
		56	56																																																											
		28	28																																																											
		51	63																																																											
		80	88																																																											
		56	56																																																											
Номинальное сечение кабеля (мм ²)		1-2.5	2.5-6																																																											
	<p>УНТ-315 УНТ-325 Ток (А): 16А, 32А Напряжение (В): 220-380В~ 240-415В~ Класс защиты: IP44</p> 	<table border="1"> <tr><td colspan="2">Пол. контакта заземл.</td><td colspan="2">6 ч</td></tr> <tr><td colspan="2">Номинальный ток (А)</td><td>16</td><td>32</td></tr> <tr><td colspan="4">Полюсы</td></tr> <tr><td colspan="4">5</td></tr> <tr><td colspan="2">Размеры (мм)</td><td>a</td><td>b</td></tr> <tr><td colspan="2"></td><td>70</td><td>71</td></tr> <tr><td colspan="2"></td><td>70</td><td>71</td></tr> <tr><td colspan="2"></td><td>56</td><td>56</td></tr> <tr><td colspan="2"></td><td>56</td><td>56</td></tr> <tr><td colspan="2"></td><td>28</td><td>28</td></tr> <tr><td colspan="2"></td><td>51</td><td>63</td></tr> <tr><td colspan="2"></td><td>80</td><td>88</td></tr> <tr><td colspan="2"></td><td>56</td><td>56</td></tr> <tr><td colspan="2">Номинальное сечение кабеля (мм²)</td><td>1-2.5</td><td>2.5-6</td></tr> </table>	Пол. контакта заземл.		6 ч		Номинальный ток (А)		16	32	Полюсы				5				Размеры (мм)		a	b			70	71			70	71			56	56			56	56			28	28			51	63			80	88			56	56	Номинальное сечение кабеля (мм ²)		1-2.5	2.5-6				
Пол. контакта заземл.		6 ч																																																												
Номинальный ток (А)		16	32																																																											
Полюсы																																																														
5																																																														
Размеры (мм)		a	b																																																											
		70	71																																																											
		70	71																																																											
		56	56																																																											
		56	56																																																											
		28	28																																																											
		51	63																																																											
		80	88																																																											
		56	56																																																											
Номинальное сечение кабеля (мм ²)		1-2.5	2.5-6																																																											
	<p>УНТ-333 УНТ-343 Ток (А): 63А, 125А Напряжение (В): 220-240В~ Класс защиты: IP67</p> 	<table border="1"> <tr><td colspan="2">Пол. контакта заземл.</td><td colspan="2">6 ч</td></tr> <tr><td colspan="2">Номинальный ток (А)</td><td>63</td><td>125</td></tr> <tr><td colspan="4">Полюсы</td></tr> <tr><td colspan="4">3</td></tr> <tr><td colspan="2">Размеры (мм)</td><td>a</td><td>b</td></tr> <tr><td colspan="2"></td><td>100</td><td>120</td></tr> <tr><td colspan="2"></td><td>100</td><td>120</td></tr> <tr><td colspan="2"></td><td>80</td><td>101</td></tr> <tr><td colspan="2"></td><td>80</td><td>101</td></tr> <tr><td colspan="2"></td><td>57</td><td>65</td></tr> <tr><td colspan="2"></td><td>86</td><td>96</td></tr> <tr><td colspan="2"></td><td>115</td><td>130</td></tr> <tr><td colspan="2"></td><td>109</td><td>124</td></tr> <tr><td colspan="2"></td><td>70</td><td>88</td></tr> <tr><td colspan="2">Номинальное сечение кабеля (мм²)</td><td>1-2.5</td><td>2.5-6</td></tr> </table>	Пол. контакта заземл.		6 ч		Номинальный ток (А)		63	125	Полюсы				3				Размеры (мм)		a	b			100	120			100	120			80	101			80	101			57	65			86	96			115	130			109	124			70	88	Номинальное сечение кабеля (мм ²)		1-2.5	2.5-6
Пол. контакта заземл.		6 ч																																																												
Номинальный ток (А)		63	125																																																											
Полюсы																																																														
3																																																														
Размеры (мм)		a	b																																																											
		100	120																																																											
		100	120																																																											
		80	101																																																											
		80	101																																																											
		57	65																																																											
		86	96																																																											
		115	130																																																											
		109	124																																																											
		70	88																																																											
Номинальное сечение кабеля (мм ²)		1-2.5	2.5-6																																																											
	<p>УНТ-334 УНТ-344 Ток (А): 63А, 125А Напряжение (В): 380-415В~ Класс защиты: IP67</p> 	<table border="1"> <tr><td colspan="2">Пол. контакта заземл.</td><td colspan="2">6 ч</td></tr> <tr><td colspan="2">Номинальный ток (А)</td><td>63</td><td>125</td></tr> <tr><td colspan="4">Полюсы</td></tr> <tr><td colspan="4">4</td></tr> <tr><td colspan="2">Размеры (мм)</td><td>a</td><td>b</td></tr> <tr><td colspan="2"></td><td>100</td><td>120</td></tr> <tr><td colspan="2"></td><td>100</td><td>120</td></tr> <tr><td colspan="2"></td><td>80</td><td>101</td></tr> <tr><td colspan="2"></td><td>80</td><td>101</td></tr> <tr><td colspan="2"></td><td>57</td><td>65</td></tr> <tr><td colspan="2"></td><td>86</td><td>96</td></tr> <tr><td colspan="2"></td><td>115</td><td>130</td></tr> <tr><td colspan="2"></td><td>109</td><td>124</td></tr> <tr><td colspan="2"></td><td>70</td><td>88</td></tr> <tr><td colspan="2">Номинальное сечение кабеля (мм²)</td><td>1-2.5</td><td>2.5-6</td></tr> </table>	Пол. контакта заземл.		6 ч		Номинальный ток (А)		63	125	Полюсы				4				Размеры (мм)		a	b			100	120			100	120			80	101			80	101			57	65			86	96			115	130			109	124			70	88	Номинальное сечение кабеля (мм ²)		1-2.5	2.5-6
Пол. контакта заземл.		6 ч																																																												
Номинальный ток (А)		63	125																																																											
Полюсы																																																														
4																																																														
Размеры (мм)		a	b																																																											
		100	120																																																											
		100	120																																																											
		80	101																																																											
		80	101																																																											
		57	65																																																											
		86	96																																																											
		115	130																																																											
		109	124																																																											
		70	88																																																											
Номинальное сечение кабеля (мм ²)		1-2.5	2.5-6																																																											
	<p>УНТ-335 УНТ-345 Ток (А): 63А, 125А Напряжение (В): 220-380В~ 240-415В~ Класс защиты: IP67</p> 	<table border="1"> <tr><td colspan="2">Пол. контакта заземл.</td><td colspan="2">6 ч</td></tr> <tr><td colspan="2">Номинальный ток (А)</td><td>63</td><td>125</td></tr> <tr><td colspan="4">Полюсы</td></tr> <tr><td colspan="4">5</td></tr> <tr><td colspan="2">Размеры (мм)</td><td>a</td><td>b</td></tr> <tr><td colspan="2"></td><td>100</td><td>120</td></tr> <tr><td colspan="2"></td><td>100</td><td>120</td></tr> <tr><td colspan="2"></td><td>80</td><td>101</td></tr> <tr><td colspan="2"></td><td>80</td><td>101</td></tr> <tr><td colspan="2"></td><td>57</td><td>65</td></tr> <tr><td colspan="2"></td><td>86</td><td>96</td></tr> <tr><td colspan="2"></td><td>115</td><td>130</td></tr> <tr><td colspan="2"></td><td>109</td><td>124</td></tr> <tr><td colspan="2"></td><td>70</td><td>88</td></tr> <tr><td colspan="2">Номинальное сечение кабеля (мм²)</td><td>1-2.5</td><td>2.5-6</td></tr> </table>	Пол. контакта заземл.		6 ч		Номинальный ток (А)		63	125	Полюсы				5				Размеры (мм)		a	b			100	120			100	120			80	101			80	101			57	65			86	96			115	130			109	124			70	88	Номинальное сечение кабеля (мм ²)		1-2.5	2.5-6
Пол. контакта заземл.		6 ч																																																												
Номинальный ток (А)		63	125																																																											
Полюсы																																																														
5																																																														
Размеры (мм)		a	b																																																											
		100	120																																																											
		100	120																																																											
		80	101																																																											
		80	101																																																											
		57	65																																																											
		86	96																																																											
		115	130																																																											
		109	124																																																											
		70	88																																																											
Номинальное сечение кабеля (мм ²)		1-2.5	2.5-6																																																											
	<p>УНТ-213-4 УНТ-223-4 Ток (А): 16А, 32А Напряжение (В): 110-130В~ Класс защиты: IP44</p> 	<table border="1"> <tr><td colspan="2">Пол. контакта заземл.</td><td colspan="2">4 ч</td></tr> <tr><td colspan="2">Номинальный ток (А)</td><td>16</td><td>32</td></tr> <tr><td colspan="4">Полюсы</td></tr> <tr><td colspan="4">3</td></tr> <tr><td colspan="2">Размеры (мм)</td><td>a</td><td>b</td></tr> <tr><td colspan="2"></td><td>131</td><td>152</td></tr> <tr><td colspan="2"></td><td>69</td><td>94</td></tr> <tr><td colspan="2"></td><td>50.5</td><td>65</td></tr> <tr><td colspan="2"></td><td>6-16</td><td>8-20</td></tr> <tr><td colspan="2">Номинальное сечение кабеля (мм²)</td><td>1-2.5</td><td>2.5-6</td></tr> </table>	Пол. контакта заземл.		4 ч		Номинальный ток (А)		16	32	Полюсы				3				Размеры (мм)		a	b			131	152			69	94			50.5	65			6-16	8-20	Номинальное сечение кабеля (мм ²)		1-2.5	2.5-6																				
Пол. контакта заземл.		4 ч																																																												
Номинальный ток (А)		16	32																																																											
Полюсы																																																														
3																																																														
Размеры (мм)		a	b																																																											
		131	152																																																											
		69	94																																																											
		50.5	65																																																											
		6-16	8-20																																																											
Номинальное сечение кабеля (мм ²)		1-2.5	2.5-6																																																											

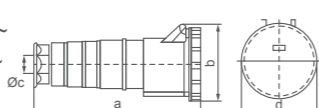
Промышленные розетки и вилки **УНТ**









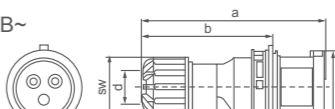

	<p>УНТ-213 УНТ-223 Ток (А): 16А, 32А Напряжение (В): 220-240В~ Класс защиты: IP44</p> 	<table border="1"> <tr><td colspan="2">Пол. контакта заземл.</td><td colspan="2">6 ч</td></tr> <tr><td colspan="2">Номинальный ток (А)</td><td>16</td><td>32</td></tr> <tr><td colspan="4">Полюсы</td></tr> <tr><td colspan="4">3</td></tr> <tr><td colspan="2">Размеры (мм)</td><td>a</td><td>b</td></tr> <tr><td colspan="2"></td><td>131</td><td>152</td></tr> <tr><td colspan="2"></td><td>69</td><td>94</td></tr> <tr><td colspan="2"></td><td>50.5</td><td>65</td></tr> <tr><td colspan="2"></td><td>6-16</td><td>8-20</td></tr> <tr><td colspan="2">Номинальное сечение кабеля (мм²)</td><td>1-2.5</td><td>2.5-6</td></tr> </table>	Пол. контакта заземл.		6 ч		Номинальный ток (А)		16	32	Полюсы				3				Размеры (мм)		a	b			131	152			69	94			50.5	65			6-16	8-20	Номинальное сечение кабеля (мм ²)		1-2.5	2.5-6
Пол. контакта заземл.		6 ч																																								
Номинальный ток (А)		16	32																																							
Полюсы																																										
3																																										
Размеры (мм)		a	b																																							
		131	152																																							
		69	94																																							
		50.5	65																																							
		6-16	8-20																																							
Номинальное сечение кабеля (мм ²)		1-2.5	2.5-6																																							
	<p>УНТ-214 УНТ-224 Ток (А): 16А, 32А Напряжение (В): 380-415В~ Класс защиты: IP44</p> 	<table border="1"> <tr><td colspan="2">Пол. контакта заземл.</td><td colspan="2">6 ч</td></tr> <tr><td colspan="2">Номинальный ток (А)</td><td>16</td><td>32</td></tr> <tr><td colspan="4">Полюсы</td></tr> <tr><td colspan="4">4</td></tr> <tr><td colspan="2">Размеры (мм)</td><td>a</td><td>b</td></tr> <tr><td colspan="2"></td><td>131</td><td>152</td></tr> <tr><td colspan="2"></td><td>69</td><td>94</td></tr> <tr><td colspan="2"></td><td>50.5</td><td>65</td></tr> <tr><td colspan="2"></td><td>6-16</td><td>8-20</td></tr> <tr><td colspan="2">Номинальное сечение кабеля (мм²)</td><td>1-2.5</td><td>2.5-6</td></tr> </table>	Пол. контакта заземл.		6 ч		Номинальный ток (А)		16	32	Полюсы				4				Размеры (мм)		a	b			131	152			69	94			50.5	65			6-16	8-20	Номинальное сечение кабеля (мм ²)		1-2.5	2.5-6
Пол. контакта заземл.		6 ч																																								
Номинальный ток (А)		16	32																																							
Полюсы																																										
4																																										
Размеры (мм)		a	b																																							
		131	152																																							
		69	94																																							
		50.5	65																																							
		6-16	8-20																																							
Номинальное сечение кабеля (мм ²)		1-2.5	2.5-6																																							
	<p>УНТ-215 УНТ-225 Ток (А): 16А, 32А Напряжение (В): 220-380В~ 240-415В~ Класс защиты: IP44</p> 	<table border="1"> <tr><td colspan="2">Пол. контакта заземл.</td><td colspan="2">6 ч</td></tr> <tr><td colspan="2">Номинальный ток (А)</td><td>16</td><td>32</td></tr> <tr><td colspan="4">Полюсы</td></tr> <tr><td colspan="4">5</td></tr> <tr><td colspan="2">Размеры (мм)</td><td>a</td><td>b</td></tr> <tr><td colspan="2"></td><td>141</td><td>154</td></tr> <tr><td colspan="2"></td><td>93</td><td>101</td></tr> <tr><td colspan="2"></td><td>64</td><td>71</td></tr> <tr><td colspan="2"></td><td>8-20</td><td>8-20</td></tr> <tr><td colspan="2">Номинальное сечение кабеля (мм²)</td><td>1-2.5</td><td>2.5-6</td></tr> </table>	Пол. контакта заземл.		6 ч		Номинальный ток (А)		16	32	Полюсы				5				Размеры (мм)		a	b			141	154			93	101			64	71			8-20	8-20	Номинальное сечение кабеля (мм ²)		1-2.5	2.5-6
Пол. контакта заземл.		6 ч																																								
Номинальный ток (А)		16	32																																							
Полюсы																																										
5																																										
Размеры (мм)		a	b																																							
		141	154																																							
		93	101																																							
		64	71																																							
		8-20	8-20																																							
Номинальное сечение кабеля (мм ²)		1-2.5	2.5-6																																							
	<p>УНТ-213L-4 УНТ-223L-4 Ток (А): 16А, 32А Напряжение (В): 110-130В~ Класс защиты: IP44</p> 	<table border="1"> <tr><td colspan="2">Пол. контакта заземл.</td><td colspan="2">4 ч</td></tr> <tr><td colspan="2">Номинальный ток (А)</td><td>16</td><td>32</td></tr> <tr><td colspan="4">Полюсы</td></tr> <tr><td colspan="4">3</td></tr> <tr><td colspan="2">Размеры (мм)</td><td>a</td><td>b</td></tr> <tr><td colspan="2"></td><td>150</td><td>182</td></tr> <tr><td colspan="2"></td><td>69</td><td>94</td></tr> <tr><td colspan="2"></td><td>50.5</td><td>65</td></tr> <tr><td colspan="2"></td><td>7-16</td><td>7-20</td></tr> <tr><td colspan="2">Номинальное сечение кабеля (мм²)</td><td>1-2.5</td><td>2.5-6</td></tr> </table>	Пол. контакта заземл.		4 ч		Номинальный ток (А)		16	32	Полюсы				3				Размеры (мм)		a	b			150	182			69	94			50.5	65			7-16	7-20	Номинальное сечение кабеля (мм ²)		1-2.5	2.5-6
Пол. контакта заземл.		4 ч																																								
Номинальный ток (А)		16	32																																							
Полюсы																																										
3																																										
Размеры (мм)		a	b																																							
		150	182																																							
		69	94																																							
		50.5	65																																							
		7-16	7-20																																							
Номинальное сечение кабеля (мм ²)		1-2.5	2.5-6																																							
	<p>УНТ-213L УНТ-223L Ток (А): 16А, 32А Напряжение (В): 220-240В~ Класс защиты: IP44</p> 	<table border="1"> <tr><td colspan="2">Пол. контакта заземл.</td><td colspan="2">6 ч</td></tr> <tr><td colspan="2">Номинальный ток (А)</td><td>63</td><td>125</td></tr> <tr><td colspan="4">Полюсы</td></tr> <tr><td colspan="4">3</td></tr> <tr><td colspan="2">Размеры (мм)</td><td>a</td><td>b</td></tr> <tr><td colspan="2"></td><td>150</td><td>182</td></tr> <tr><td colspan="2"></td><td>69</td><td>94</td></tr> <tr><td colspan="2"></td><td>50.5</td><td>65</td></tr> <tr><td colspan="2"></td><td>7-16</td><td>7-20</td></tr> <tr><td colspan="2">Номинальное сечение кабеля (мм²)</td><td>6-16</td><td>16-50</td></tr> </table>	Пол. контакта заземл.		6 ч		Номинальный ток (А)		63	125	Полюсы				3				Размеры (мм)		a	b			150	182			69	94			50.5	65			7-16	7-20	Номинальное сечение кабеля (мм ²)		6-16	16-50
Пол. контакта заземл.		6 ч																																								
Номинальный ток (А)		63	125																																							
Полюсы																																										
3																																										
Размеры (мм)		a	b																																							
		150	182																																							
		69	94																																							
		50.5	65																																							
		7-16	7-20																																							
Номинальное сечение кабеля (мм ²)		6-16	16-50																																							
	<p>УНТ-214L УНТ-224L Ток (А): 16А, 32А Напряжение (В): 380-415В~ Класс защиты: IP44</p> 	<table border="1"> <tr><td colspan="2">Пол. контакта заземл.</td><td colspan="2">6 ч</td></tr> <tr><td colspan="2">Номинальный ток (А)</td><td>63</td><td>32</td></tr> <tr><td colspan="4">Полюсы</td></tr> <tr><td colspan="4">4</td></tr> <tr><td colspan="2">Размеры (мм)</td><td>a</td><td>b</td></tr> <tr><td colspan="2"></td><td>150</td><td>182</td></tr> <tr><td colspan="2"></td><td>79</td><td>94</td></tr> <tr><td colspan="2"></td><td>56</td><td>65</td></tr> <tr><td colspan="2"></td><td>7-16</td><td>7-20</td></tr> <tr><td colspan="2">Номинальное сечение кабеля (мм²)</td><td>6-16</td><td>16-50</td></tr> </table>	Пол. контакта заземл.		6 ч		Номинальный ток (А)		63	32	Полюсы				4				Размеры (мм)		a	b			150	182			79	94			56	65			7-16	7-20	Номинальное сечение кабеля (мм ²)		6-16	16-50
Пол. контакта заземл.		6 ч																																								
Номинальный ток (А)		63	32																																							
Полюсы																																										
4																																										
Размеры (мм)		a	b																																							
		150	182																																							
		79	94																																							
		56	65																																							
		7-16	7-20																																							
Номинальное сечение кабеля (мм ²)		6-16	16-50																																							

Промышленные розетки и вилки **YHT**

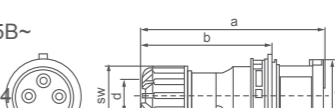
	<p>YHT-215L YHT-225L Ток (А): 16А, 32А Напряжение (В): 220-380В~ 240-415В~ Класс защиты: IP44</p>  <p>3P+N+E</p>	<table border="1"> <tr><td>Пол. контакта заземл.</td><td colspan="2">6 ч</td></tr> <tr><td>Номинальный ток (А)</td><td>16</td><td>32</td></tr> <tr><td>Полюсы</td><td colspan="2">5</td></tr> <tr><td rowspan="4">Размеры (мм)</td><td>a</td><td>171</td><td>185</td></tr> <tr><td>b</td><td>93</td><td>101</td></tr> <tr><td>c</td><td>64</td><td>71</td></tr> <tr><td>Ø</td><td>7-20</td><td>7-20</td></tr> <tr><td>Номинальное сечение кабеля (мм²)</td><td>1-2.5</td><td>2.5-6</td></tr> </table>	Пол. контакта заземл.	6 ч		Номинальный ток (А)	16	32	Полюсы	5		Размеры (мм)	a	171	185	b	93	101	c	64	71	Ø	7-20	7-20	Номинальное сечение кабеля (мм ²)	1-2.5	2.5-6
Пол. контакта заземл.	6 ч																										
Номинальный ток (А)	16	32																									
Полюсы	5																										
Размеры (мм)	a	171	185																								
	b	93	101																								
	c	64	71																								
	Ø	7-20	7-20																								
Номинальное сечение кабеля (мм ²)	1-2.5	2.5-6																									
	<p>YHT-233 YHT-243 Ток (А): 63А, 125А Напряжение (В): 220-240В~ Класс защиты: IP67</p>  <p>2P+E</p>	<table border="1"> <tr><td>Пол. контакта заземл.</td><td colspan="2">6 ч</td></tr> <tr><td>Номинальный ток (А)</td><td>63</td><td>125</td></tr> <tr><td>Полюсы</td><td colspan="2">3</td></tr> <tr><td rowspan="4">Размеры (мм)</td><td>a</td><td>240</td><td>309</td></tr> <tr><td>b</td><td>115</td><td>129</td></tr> <tr><td>c</td><td>16-38</td><td>30-64</td></tr> <tr><td>Ø</td><td>108</td><td>123</td></tr> <tr><td>Номинальное сечение кабеля (мм²)</td><td>6-16</td><td>16-50</td></tr> </table>	Пол. контакта заземл.	6 ч		Номинальный ток (А)	63	125	Полюсы	3		Размеры (мм)	a	240	309	b	115	129	c	16-38	30-64	Ø	108	123	Номинальное сечение кабеля (мм ²)	6-16	16-50
Пол. контакта заземл.	6 ч																										
Номинальный ток (А)	63	125																									
Полюсы	3																										
Размеры (мм)	a	240	309																								
	b	115	129																								
	c	16-38	30-64																								
	Ø	108	123																								
Номинальное сечение кабеля (мм ²)	6-16	16-50																									
	<p>YHT-234 YHT-244 Ток (А): 63А, 125А Напряжение (В): 380-415В~ Класс защиты: IP67</p>  <p>3P+E</p>	<table border="1"> <tr><td>Пол. контакта заземл.</td><td colspan="2">6 ч</td></tr> <tr><td>Номинальный ток (А)</td><td>63</td><td>125</td></tr> <tr><td>Полюсы</td><td colspan="2">4</td></tr> <tr><td rowspan="4">Размеры (мм)</td><td>a</td><td>240</td><td>309</td></tr> <tr><td>b</td><td>115</td><td>129</td></tr> <tr><td>c</td><td>16-38</td><td>30-64</td></tr> <tr><td>Ø</td><td>108</td><td>123</td></tr> <tr><td>Номинальное сечение кабеля (мм²)</td><td>6-16</td><td>16-50</td></tr> </table>	Пол. контакта заземл.	6 ч		Номинальный ток (А)	63	125	Полюсы	4		Размеры (мм)	a	240	309	b	115	129	c	16-38	30-64	Ø	108	123	Номинальное сечение кабеля (мм ²)	6-16	16-50
Пол. контакта заземл.	6 ч																										
Номинальный ток (А)	63	125																									
Полюсы	4																										
Размеры (мм)	a	240	309																								
	b	115	129																								
	c	16-38	30-64																								
	Ø	108	123																								
Номинальное сечение кабеля (мм ²)	6-16	16-50																									
	<p>YHT-235 YHT-245 Ток (А): 63А, 125А Напряжение (В): 220-380В~ 240-415В~ Класс защиты: IP67</p>  <p>3P+N+E</p>	<table border="1"> <tr><td>Пол. контакта заземл.</td><td colspan="2">6 ч</td></tr> <tr><td>Номинальный ток (А)</td><td>63</td><td>125</td></tr> <tr><td>Полюсы</td><td colspan="2">5</td></tr> <tr><td rowspan="4">Размеры (мм)</td><td>a</td><td>240</td><td>309</td></tr> <tr><td>b</td><td>115</td><td>129</td></tr> <tr><td>c</td><td>16-38</td><td>30-64</td></tr> <tr><td>Ø</td><td>108</td><td>123</td></tr> <tr><td>Номинальное сечение кабеля (мм²)</td><td>6-16</td><td>16-50</td></tr> </table>	Пол. контакта заземл.	6 ч		Номинальный ток (А)	63	125	Полюсы	5		Размеры (мм)	a	240	309	b	115	129	c	16-38	30-64	Ø	108	123	Номинальное сечение кабеля (мм ²)	6-16	16-50
Пол. контакта заземл.	6 ч																										
Номинальный ток (А)	63	125																									
Полюсы	5																										
Размеры (мм)	a	240	309																								
	b	115	129																								
	c	16-38	30-64																								
	Ø	108	123																								
Номинальное сечение кабеля (мм ²)	6-16	16-50																									

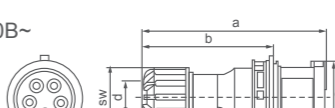
<p>YHT-1012-4 Вход: 1 вилка 16А 110В Выход: 2 розетки 16А 110В Класс защиты: IP44</p>  <p>2P+E</p>	<p>YHT-1013-4 Вход: 1 вилка 16А 110В Выход: 3 розетки 16А 110В Класс защиты: IP44</p>  <p>2P+E</p>	<p>YHT-1012 YHT-1022 Вход: 1 вилка 16А~32А 220В Выход: 2 розетки 16А~32А 220В Класс защиты: IP44</p>  <p>2P+E</p>
<p>YHT-1013 YHT-1023 Вход: 1 вилка 16А~32А 220В Выход: 3 розетки 16А~32А 220В Класс защиты: IP44</p>  <p>2P+E</p>	<p>YHT-1014/2 YHT-1024/2 Вход: 1 вилка 16А~32А 380В Выход: 2 розетки 16А~32А 380В Класс защиты: IP44</p>  <p>3P+E</p>	<p>YHT-1014 YHT-1024 Вход: 1 вилка 16А~32А 380В Выход: 3 розетки 16А~32А 380В Класс защиты: IP44</p>  <p>3P+E</p>

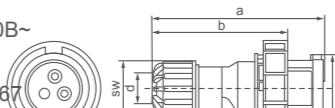

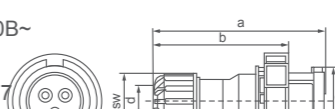





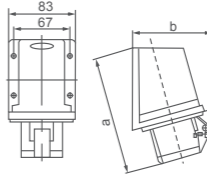

Монтируемые штепсельные соединения **YHT-N**

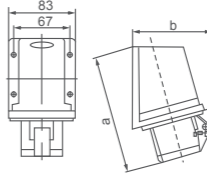
	<p>YHT-N013-4 YHT-N023-4 Ток (А): 16А, 32А Напряжение (В): 110-130В~ 2P+E Класс защиты: IP44</p> 	<table border="1"> <tr><td>Пол. контакта заземл.</td><td colspan="2">4 ч</td></tr> <tr><td>Номинальный ток (А)</td><td>16</td><td>32</td></tr> <tr><td>Полюсы</td><td colspan="2">3</td></tr> <tr><td rowspan="4">Размеры (мм)</td><td>a</td><td>118</td><td>146</td></tr> <tr><td>b</td><td>82</td><td>100</td></tr> <tr><td>c</td><td>47</td><td>63</td></tr> <tr><td>d</td><td>6-15</td><td>10-20</td></tr> <tr><td>sw</td><td>38</td><td>50</td></tr> <tr><td>Номинальное сечение кабеля (мм²)</td><td>1-2.5</td><td>2.5-6</td></tr> </table>	Пол. контакта заземл.	4 ч		Номинальный ток (А)	16	32	Полюсы	3		Размеры (мм)	a	118	146	b	82	100	c	47	63	d	6-15	10-20	sw	38	50	Номинальное сечение кабеля (мм ²)	1-2.5	2.5-6
Пол. контакта заземл.	4 ч																													
Номинальный ток (А)	16	32																												
Полюсы	3																													
Размеры (мм)	a	118	146																											
	b	82	100																											
	c	47	63																											
	d	6-15	10-20																											
sw	38	50																												
Номинальное сечение кабеля (мм ²)	1-2.5	2.5-6																												
	<p>YHT-N013 YHT-N023 Ток (А): 16А, 32А Напряжение (В): 220-240В~ 2P+E Класс защиты: IP44</p> 	<table border="1"> <tr><td>Пол. контакта заземл.</td><td colspan="2">6 ч</td></tr> <tr><td>Номинальный ток (А)</td><td>16</td><td>32</td></tr> <tr><td>Полюсы</td><td colspan="2">3</td></tr> <tr><td rowspan="4">Размеры (мм)</td><td>a</td><td>118</td><td>146</td></tr> <tr><td>b</td><td>82</td><td>100</td></tr> <tr><td>c</td><td>47</td><td>63</td></tr> <tr><td>d</td><td>6-15</td><td>10-20</td></tr> <tr><td>sw</td><td>38</td><td>50</td></tr> <tr><td>Номинальное сечение кабеля (мм²)</td><td>1-2.5</td><td>2.5-6</td></tr> </table>	Пол. контакта заземл.	6 ч		Номинальный ток (А)	16	32	Полюсы	3		Размеры (мм)	a	118	146	b	82	100	c	47	63	d	6-15	10-20	sw	38	50	Номинальное сечение кабеля (мм ²)	1-2.5	2.5-6
Пол. контакта заземл.	6 ч																													
Номинальный ток (А)	16	32																												
Полюсы	3																													
Размеры (мм)	a	118	146																											
	b	82	100																											
	c	47	63																											
	d	6-15	10-20																											
sw	38	50																												
Номинальное сечение кабеля (мм ²)	1-2.5	2.5-6																												
	<p>YHT-N014 YHT-N024 Ток (А): 16А, 32А Напряжение (В): 380-415В~ 3P+E Класс защиты: IP44</p> 	<table border="1"> <tr><td>Пол. контакта заземл.</td><td colspan="2">6 ч</td></tr> <tr><td>Номинальный ток (А)</td><td>16</td><td>32</td></tr> <tr><td>Полюсы</td><td colspan="2">4</td></tr> <tr><td rowspan="4">Размеры (мм)</td><td>a</td><td>124</td><td>146</td></tr> <tr><td>b</td><td>88</td><td>100</td></tr> <tr><td>c</td><td>53</td><td>63</td></tr> <tr><td>d</td><td>6-15</td><td>10-20</td></tr> <tr><td>sw</td><td>38</td><td>50</td></tr> <tr><td>Номинальное сечение кабеля (мм²)</td><td>1-2.5</td><td>2.5-6</td></tr> </table>	Пол. контакта заземл.	6 ч		Номинальный ток (А)	16	32	Полюсы	4		Размеры (мм)	a	124	146	b	88	100	c	53	63	d	6-15	10-20	sw	38	50	Номинальное сечение кабеля (мм ²)	1-2.5	2.5-6
Пол. контакта заземл.	6 ч																													
Номинальный ток (А)	16	32																												
Полюсы	4																													
Размеры (мм)	a	124	146																											
	b	88	100																											
	c	53	63																											
	d	6-15	10-20																											
sw	38	50																												
Номинальное сечение кабеля (мм ²)	1-2.5	2.5-6																												
	<p>YHT-N015 YHT-N025 Ток (А): 16А, 32А Напряжение (В): 220-380В~ 240-415В~ 3P+N+E Класс защиты: IP44</p> 	<table border="1"> <tr><td>Пол. контакта заземл.</td><td colspan="2">6 ч</td></tr> <tr><td>Номинальный ток (А)</td><td>16</td><td>32</td></tr> <tr><td>Полюсы</td><td colspan="2">5</td></tr> <tr><td rowspan="4">Размеры (мм)</td><td>a</td><td>131</td><td>152</td></tr> <tr><td>b</td><td>95</td><td>106</td></tr> <tr><td>c</td><td>61</td><td>70</td></tr> <tr><td>d</td><td>8-16</td><td>10-20</td></tr> <tr><td>sw</td><td>42</td><td>50</td></tr> <tr><td>Номинальное сечение кабеля (мм²)</td><td>1-2.5</td><td>2.5-6</td></tr> </table>	Пол. контакта заземл.	6 ч		Номинальный ток (А)	16	32	Полюсы	5		Размеры (мм)	a	131	152	b	95	106	c	61	70	d	8-16	10-20	sw	42	50	Номинальное сечение кабеля (мм ²)	1-2.5	2.5-6
Пол. контакта заземл.	6 ч																													
Номинальный ток (А)	16	32																												
Полюсы	5																													
Размеры (мм)	a	131	152																											
	b	95	106																											
	c	61	70																											
	d	8-16	10-20																											
sw	42	50																												
Номинальное сечение кабеля (мм ²)	1-2.5	2.5-6																												
	<p>YHT-N0132-4 YHT-N0232-4 Ток (А): 16А, 32А Напряжение (В): 110-130В~ 2P+E Класс защиты: IP67</p> 	<table border="1"> <tr><td>Пол. контакта заземл.</td><td colspan="2">4 ч</td></tr> <tr><td>Номинальный ток (А)</td><td>16</td><td>32</td></tr> <tr><td>Полюсы</td><td colspan="2">3</td></tr> <tr><td rowspan="4">Размеры (мм)</td><td>a</td><td>118</td><td>146</td></tr> <tr><td>b</td><td>82</td><td>100</td></tr> <tr><td>c</td><td>47</td><td>63</td></tr> <tr><td>d</td><td>6-15</td><td>10-20</td></tr> <tr><td>sw</td><td>38</td><td>50</td></tr> <tr><td>Номинальное сечение кабеля (мм²)</td><td>1-2.5</td><td>2.5-6</td></tr> </table>	Пол. контакта заземл.	4 ч		Номинальный ток (А)	16	32	Полюсы	3		Размеры (мм)	a	118	146	b	82	100	c	47	63	d	6-15	10-20	sw	38	50	Номинальное сечение кабеля (мм ²)	1-2.5	2.5-6
Пол. контакта заземл.	4 ч																													
Номинальный ток (А)	16	32																												
Полюсы	3																													
Размеры (мм)	a	118	146																											
	b	82	100																											
	c	47	63																											
	d	6-15	10-20																											
sw	38	50																												
Номинальное сечение кабеля (мм ²)	1-2.5	2.5-6																												
	<p>YHT-N0132 YHT-N0232 Ток (А): 16А, 32А Напряжение (В): 220-240В~ 3P+E Класс защиты: IP67</p> 	<table border="1"> <tr><td>Пол. контакта заземл.</td><td colspan="2">6 ч</td></tr> <tr><td>Номинальный ток (А)</td><td>16</td><td>32</td></tr> <tr><td>Полюсы</td><td colspan="2">3</td></tr> <tr><td rowspan="4">Размеры (мм)</td><td>a</td><td>118</td><td>146</td></tr> <tr><td>b</td><td>82</td><td>100</td></tr> <tr><td>c</td><td>6-15</td><td>10-20</td></tr> <tr><td>sw</td><td>38</td><td>50</td></tr> <tr><td>Номинальное сечение кабеля (мм²)</td><td>1-2.5</td><td>2.5-6</td></tr> </table>	Пол. контакта заземл.	6 ч		Номинальный ток (А)	16	32	Полюсы	3		Размеры (мм)	a	118	146	b	82	100	c	6-15	10-20	sw	38	50	Номинальное сечение кабеля (мм ²)	1-2.5	2.5-6			
Пол. контакта заземл.	6 ч																													
Номинальный ток (А)	16	32																												
Полюсы	3																													
Размеры (мм)	a	118	146																											
	b	82	100																											
	c	6-15	10-20																											
	sw	38	50																											
Номинальное сечение кабеля (мм ²)	1-2.5	2.5-6																												

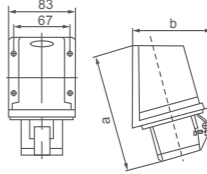

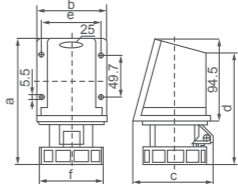

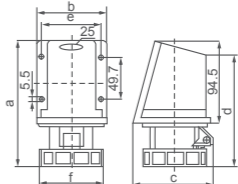

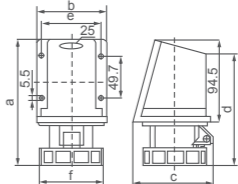

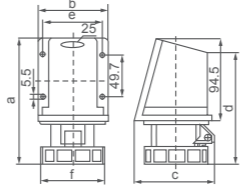

Монтируемые штепсельные соединения **YHT-N**

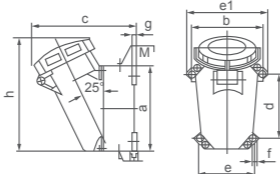
	<p>YHT-N0142 YHT-N0242 Ток (А): 16А, 32А Напряжение (В): 380-415В~ 3P+E Класс защиты: IP67</p> 	<table border="1"> <tr><td>Пол. контакта заземл.</td><td colspan="2">6 ч</td></tr> <tr><td>Номинальный ток (А)</td><td>16</td><td>32</td></tr> <tr><td>Полюсы</td><td colspan="2">4</td></tr> <tr><td rowspan="4">Размеры (мм)</td><td>a</td><td>124</td><td>146</td></tr> <tr><td>b</td><td>79</td><td>93</td></tr> <tr><td>c</td><td>6-15</td><td>10-20</td></tr> <tr><td>sw</td><td>38</td><td>50</td></tr> <tr><td>Номинальное сечение кабеля (мм²)</td><td>1-2.5</td><td>2.5-6</td></tr> </table>	Пол. контакта заземл.	6 ч		Номинальный ток (А)	16	32	Полюсы	4		Размеры (мм)	a	124	146	b	79	93	c	6-15	10-20	sw	38	50	Номинальное сечение кабеля (мм ²)	1-2.5	2.5-6			
Пол. контакта заземл.	6 ч																													
Номинальный ток (А)	16	32																												
Полюсы	4																													
Размеры (мм)	a	124	146																											
	b	79	93																											
	c	6-15	10-20																											
	sw	38	50																											
Номинальное сечение кабеля (мм ²)	1-2.5	2.5-6																												
	<p>YHT-N0152 YHT-N0252 Ток (А): 16А, 32А Напряжение (В): 220-380В~ 240-415В~ 3P+N+E Класс защиты: IP67</p> 	<table border="1"> <tr><td>Пол. контакта заземл.</td><td colspan="2">6 ч</td></tr> <tr><td>Номинальный ток (А)</td><td>16</td><td>32</td></tr> <tr><td>Полюсы</td><td colspan="2">5</td></tr> <tr><td rowspan="5">Размеры (мм)</td><td>a</td><td>131</td><td>152</td></tr> <tr><td>b</td><td>87</td><td>100</td></tr> <tr><td>c</td><td>8-16</td><td>10-20</td></tr> <tr><td>d</td><td>42</td><td>50</td></tr> <tr><td>sw</td><td></td><td></td></tr> <tr><td>Номинальное сечение кабеля (мм²)</td><td>1-2.5</td><td>2.5-6</td></tr> </table>	Пол. контакта заземл.	6 ч		Номинальный ток (А)	16	32	Полюсы	5		Размеры (мм)	a	131	152	b	87	100	c	8-16	10-20	d	42	50	sw			Номинальное сечение кабеля (мм ²)	1-2.5	2.5-6
Пол. контакта заземл.	6 ч																													
Номинальный ток (А)	16	32																												
Полюсы	5																													
Размеры (мм)	a	131	152																											
	b	87	100																											
	c	8-16	10-20																											
	d	42	50																											
	sw																													
Номинальное сечение кабеля (мм ²)	1-2.5	2.5-6																												
	<p>YHT-N0332 YHT-N0432 Ток (А): 63А, 125А Напряжение (В): 220-250В~ 2P+E Класс защиты: IP67</p> 	<table border="1"> <tr><td>Пол. контакта заземл.</td><td colspan="2">6 ч</td></tr> <tr><td>Номинальный ток (А)</td><td>63</td><td>125</td></tr> <tr><td>Полюсы</td><td colspan="2">3</td></tr> <tr><td rowspan="5">Размеры (мм)</td><td>a</td><td>133</td><td>286</td></tr> <tr><td>b</td><td>75.5</td><td>219</td></tr> <tr><td>c</td><td>36.5</td><td>57</td></tr> <tr><td>d</td><td>240</td><td>286</td></tr> <tr><td>e</td><td>188</td><td>229</td></tr> <tr><td>Номинальное сечение кабеля (мм²)</td><td>6-16</td><td>16-50</td></tr> </table>	Пол. контакта заземл.	6 ч		Номинальный ток (А)	63	125	Полюсы	3		Размеры (мм)	a	133	286	b	75.5	219	c	36.5	57	d	240	286	e	188	229	Номинальное сечение кабеля (мм ²)	6-16	16-50
Пол. контакта заземл.	6 ч																													
Номинальный ток (А)	63	125																												
Полюсы	3																													
Размеры (мм)	a	133	286																											
	b	75.5	219																											
	c	36.5	57																											
	d	240	286																											
	e	188	229																											
Номинальное сечение кабеля (мм ²)	6-16	16-50																												
	<p>YHT-N0342 YHT-N0442 Ток (А): 63А, 125А Напряжение (В): 380-415В~ 3P+E Класс защиты: IP67</p> 	<table border="1"> <tr><td>Пол. контакта заземл.</td><td colspan="2">6 ч</td></tr> <tr><td>Номинальный ток (А)</td><td>63</td><td>125</td></tr> <tr><td>Полюсы</td><td colspan="2">4</td></tr> <tr><td rowspan="5">Размеры (мм)</td><td>a</td><td>133</td><td>286</td></tr> <tr><td>b</td><td>75.5</td><td>219</td></tr> <tr><td>c</td><td>36.5</td><td>57</td></tr> <tr><td>d</td><td>240</td><td>286</td></tr> <tr><td>e</td><td>188</td><td>229</td></tr> <tr><td>Номинальное сечение кабеля (мм²)</td><td>6-16</td><td>16-50</td></tr> </table>	Пол. контакта заземл.	6 ч		Номинальный ток (А)	63	125	Полюсы	4		Размеры (мм)	a	133	286	b	75.5	219	c	36.5	57	d	240	286	e	188	229	Номинальное сечение кабеля (мм ²)	6-16	16-50
Пол. контакта заземл.	6 ч																													
Номинальный ток (А)	63	125																												
Полюсы	4																													
Размеры (мм)	a	133	286																											
	b	75.5	219																											
	c	36.5	57																											
	d	240	286																											
	e	188	229																											
Номинальное сечение кабеля (мм ²)	6-16	16-50																												
	<p>YHT-N0352 YHT-N0452 Ток (А): 16А, 32А Напряжение (В): 220-380В~ 240-415В~ 3P+N+E Класс защиты: IP67</p> 	<table border="1"> <tr><td>Пол. контакта заземл.</td><td colspan="2">6 ч</td></tr> <tr><td>Номинальный ток (А)</td><td>16</td><td>32</td></tr> <tr><td>Полюсы</td><td colspan="2">5</td></tr> <tr><td rowspan="5">Размеры (мм)</td><td>a</td><td>133</td><td>286</td></tr> <tr><td>b</td><td>75.5</td><td>219</td></tr> <tr><td>c</td><td>36.5</td><td>57</td></tr> <tr><td>d</td><td>240</td><td>286</td></tr> <tr><td>e</td><td>188</td><td>229</td></tr> <tr><td>Номинальное сечение кабеля (мм²)</td><td>6-16</td><td>16-50</td></tr> </table>	Пол. контакта заземл.	6 ч		Номинальный ток (А)	16	32	Полюсы	5		Размеры (мм)	a	133	286	b	75.5	219	c	36.5	57	d	240	286	e	188	229	Номинальное сечение кабеля (мм ²)	6-16	16-50
Пол. контакта заземл.	6 ч																													
Номинальный ток (А)	16	32																												
Полюсы	5																													
Размеры (мм)	a	133	286																											
	b	75.5	219																											
	c	36.5	57																											
	d	240	286																											
	e	188	229																											
Номинальное сечение кабеля (мм ²)	6-16	16-50																												
	<p>YHT-N113-4 YHT-N123-4 Ток (А): 16А, 32А Напряжение (В): 110-130В~ 2P+E Класс защиты: IP44</p> 	<table border="1"> <tr><td>Пол. контакта заземл.</td><td colspan="2">4 ч</td></tr> <tr><td>Номинальный ток (А)</td><td>16</td><td>32</td></tr> <tr><td>Полюсы</td><td colspan="2">3</td></tr> <tr><td rowspan="2">Размеры (мм)</td><td>a</td><td>137</td><td>153</td></tr> <tr><td>b</td><td>84</td><td>101</td></tr> <tr><td>Номинальное сечение кабеля (мм²)</td><td>1-2.5</td><td>2.5-6</td></tr> </table>	Пол. контакта заземл.	4 ч		Номинальный ток (А)	16	32	Полюсы	3		Размеры (мм)	a	137	153	b	84	101	Номинальное сечение кабеля (мм ²)	1-2.5	2.5-6									
Пол. контакта заземл.	4 ч																													
Номинальный ток (А)	16	32																												
Полюсы	3																													
Размеры (мм)	a	137	153																											
	b	84	101																											
Номинальное сечение кабеля (мм ²)	1-2.5	2.5-6																												

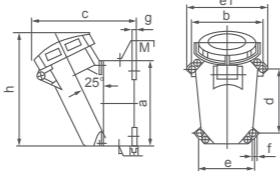

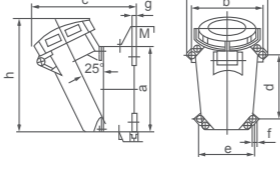

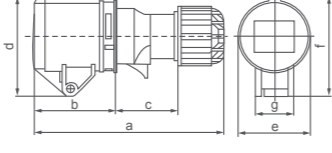

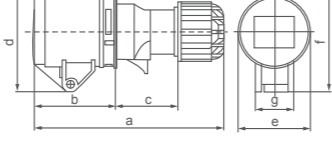

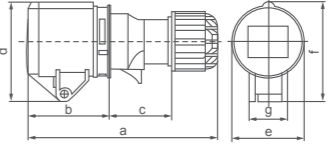

Монтируемые штепсельные соединения **YHT-N**

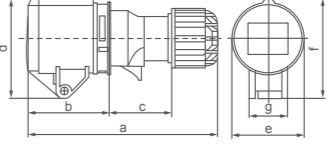
	<p>YHT-N113 YHT-N123 Ток (А): 16А, 32А Напряжение (В): 220-240В~ 2P+E Класс защиты: IP44</p> 	<table border="1"> <tr><td>Пол. контакта заземл.</td><td colspan="2">6 ч</td></tr> <tr><td>Номинальный ток (А)</td><td>16</td><td>32</td></tr> <tr><td>Полюсы</td><td colspan="2">3</td></tr> <tr><td rowspan="2">Размеры (мм)</td><td>a</td><td>137</td><td>153</td></tr> <tr><td>b</td><td>84</td><td>101</td></tr> <tr><td>Номинальное сечение кабеля (мм²)</td><td>1-2.5</td><td>2.5-6</td></tr> </table>	Пол. контакта заземл.	6 ч		Номинальный ток (А)	16	32	Полюсы	3		Размеры (мм)	a	137	153	b	84	101	Номинальное сечение кабеля (мм ²)	1-2.5	2.5-6												
Пол. контакта заземл.	6 ч																																
Номинальный ток (А)	16	32																															
Полюсы	3																																
Размеры (мм)	a	137	153																														
	b	84	101																														
Номинальное сечение кабеля (мм ²)	1-2.5	2.5-6																															
	<p>YHT-N114 YHT-N124 Ток (А): 16А, 32А Напряжение (В): 380-415В~ 3P+E Класс защиты: IP44</p> 	<table border="1"> <tr><td>Пол. контакта заземл.</td><td colspan="2">6 ч</td></tr> <tr><td>Номинальный ток (А)</td><td>16</td><td>32</td></tr> <tr><td>Полюсы</td><td colspan="2">4</td></tr> <tr><td rowspan="2">Размеры (мм)</td><td>a</td><td>139</td><td>153</td></tr> <tr><td>b</td><td>95</td><td>101</td></tr> <tr><td>Номинальное сечение кабеля (мм²)</td><td>1-2.5</td><td>2.5-6</td></tr> </table>	Пол. контакта заземл.	6 ч		Номинальный ток (А)	16	32	Полюсы	4		Размеры (мм)	a	139	153	b	95	101	Номинальное сечение кабеля (мм ²)	1-2.5	2.5-6												
Пол. контакта заземл.	6 ч																																
Номинальный ток (А)	16	32																															
Полюсы	4																																
Размеры (мм)	a	139	153																														
	b	95	101																														
Номинальное сечение кабеля (мм ²)	1-2.5	2.5-6																															
	<p>YHT-N115 YHT-N125 Ток (А): 16А, 32А Напряжение (В): 220-380В~ 240-415В~ 3P+N+E Класс защиты: IP44</p> 	<table border="1"> <tr><td>Пол. контакта заземл.</td><td colspan="2">6 ч</td></tr> <tr><td>Номинальный ток (А)</td><td>63</td><td>125</td></tr> <tr><td>Полюсы</td><td colspan="2">5</td></tr> <tr><td rowspan="2">Размеры (мм)</td><td>a</td><td>139</td><td>154</td></tr> <tr><td>b</td><td>99</td><td>104</td></tr> <tr><td>Номинальное сечение кабеля (мм²)</td><td>1-2.5</td><td>2.5-6</td></tr> </table>	Пол. контакта заземл.	6 ч		Номинальный ток (А)	63	125	Полюсы	5		Размеры (мм)	a	139	154	b	99	104	Номинальное сечение кабеля (мм ²)	1-2.5	2.5-6												
Пол. контакта заземл.	6 ч																																
Номинальный ток (А)	63	125																															
Полюсы	5																																
Размеры (мм)	a	139	154																														
	b	99	104																														
Номинальное сечение кабеля (мм ²)	1-2.5	2.5-6																															
	<p>YHT-N1132-4 YHT-N1232-4 Ток (А): 16А, 32А Напряжение (В): 110-130В~ 2P+E Класс защиты: IP67</p> 	<table border="1"> <tr><td>Пол. контакта заземл.</td><td colspan="2">4 ч</td></tr> <tr><td>Номинальный ток (А)</td><td>16</td><td>32</td></tr> <tr><td>Полюсы</td><td colspan="2">3</td></tr> <tr><td rowspan="6">Размеры (мм)</td><td>a</td><td>144</td><td>154</td></tr> <tr><td>b</td><td>80</td><td>80</td></tr> <tr><td>c</td><td>92.2</td><td>98.7</td></tr> <tr><td>d</td><td>129</td><td>133</td></tr> <tr><td>e</td><td>67.7</td><td>67.7</td></tr> <tr><td>f</td><td>71.5</td><td>93</td></tr> <tr><td>Номинальное сечение кабеля (мм²)</td><td>1-2.5</td><td>4-6</td></tr> </table>	Пол. контакта заземл.	4 ч		Номинальный ток (А)	16	32	Полюсы	3		Размеры (мм)	a	144	154	b	80	80	c	92.2	98.7	d	129	133	e	67.7	67.7	f	71.5	93	Номинальное сечение кабеля (мм ²)	1-2.5	4-6
Пол. контакта заземл.	4 ч																																
Номинальный ток (А)	16	32																															
Полюсы	3																																
Размеры (мм)	a	144	154																														
	b	80	80																														
	c	92.2	98.7																														
	d	129	133																														
	e	67.7	67.7																														
	f	71.5	93																														
Номинальное сечение кабеля (мм ²)	1-2.5	4-6																															
	<p>YHT-N1132 YHT-N1232 Ток (А): 16А, 32А Напряжение (В): 220-240В~ 2P+E Класс защиты: IP67</p> 	<table border="1"> <tr><td>Пол. контакта заземл.</td><td colspan="2">6 ч</td></tr> <tr><td>Номинальный ток (А)</td><td>16</td><td>32</td></tr> <tr><td>Полюсы</td><td colspan="2">3</td></tr> <tr><td rowspan="6">Размеры (мм)</td><td>a</td><td>144</td><td>154</td></tr> <tr><td>b</td><td>80</td><td>80</td></tr> <tr><td>c</td><td>92.2</td><td>98.7</td></tr> <tr><td>d</td><td>129</td><td>133</td></tr> <tr><td>e</td><td>67.7</td><td>67.7</td></tr> <tr><td>f</td><td>71.5</td><td>93</td></tr> <tr><td>Номинальное сечение кабеля (мм²)</td><td>1-2.5</td><td>4-6</td></tr> </table>	Пол. контакта заземл.	6 ч		Номинальный ток (А)	16	32	Полюсы	3		Размеры (мм)	a	144	154	b	80	80	c	92.2	98.7	d	129	133	e	67.7	67.7	f	71.5	93	Номинальное сечение кабеля (мм ²)	1-2.5	4-6
Пол. контакта заземл.	6 ч																																
Номинальный ток (А)	16	32																															
Полюсы	3																																
Размеры (мм)	a	144	154																														
	b	80	80																														
	c	92.2	98.7																														
	d	129	133																														
	e	67.7	67.7																														
	f	71.5	93																														
Номинальное сечение кабеля (мм ²)	1-2.5	4-6																															
	<p>YHT-N1142 YHT-N1242 Ток (А): 16А, 32А Напряжение (В): 380-415В~ 3P+E Класс защиты: IP67</p> 	<table border="1"> <tr><td>Пол. контакта заземл.</td><td colspan="2">6 ч</td></tr> <tr><td>Номинальный ток (А)</td><td>16</td><td>32</td></tr> <tr><td>Полюсы</td><td colspan="2">4</td></tr> <tr><td rowspan="6">Размеры (мм)</td><td>a</td><td>144</td><td>154</td></tr> <tr><td>b</td><td>80</td><td>80</td></tr> <tr><td>c</td><td>94.2</td><td>98.7</td></tr> <tr><td>d</td><td>129</td><td>138</td></tr> <tr><td>e</td><td>67.7</td><td>67.7</td></tr> <tr><td>f</td><td>79</td><td>93</td></tr> <tr><td>Номинальное сечение кабеля (мм²)</td><td>1-2.5</td><td>4-6</td></tr> </table>	Пол. контакта заземл.	6 ч		Номинальный ток (А)	16	32	Полюсы	4		Размеры (мм)	a	144	154	b	80	80	c	94.2	98.7	d	129	138	e	67.7	67.7	f	79	93	Номинальное сечение кабеля (мм ²)	1-2.5	4-6
Пол. контакта заземл.	6 ч																																
Номинальный ток (А)	16	32																															
Полюсы	4																																
Размеры (мм)	a	144	154																														
	b	80	80																														
	c	94.2	98.7																														
	d	129	138																														
	e	67.7	67.7																														
	f	79	93																														
Номинальное сечение кабеля (мм ²)	1-2.5	4-6																															

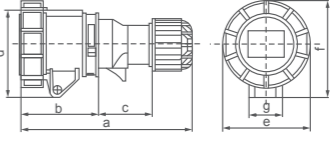

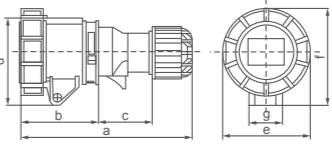

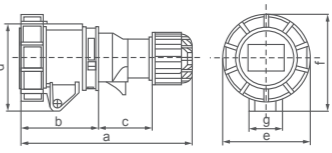

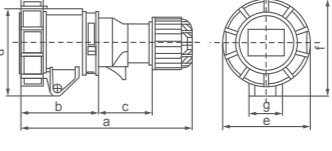

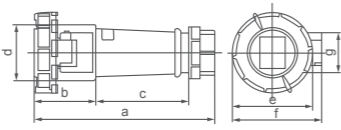

Монтируемые штепсельные соединения УНТ-N

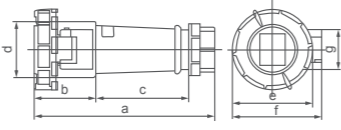
	<p>УНТ-N1152 УНТ-N1252 Ток (А): 16А, 32А Напряжение (В): 220-380В~ 240-415В~ 3P+N+E Класс защиты: IP67</p> 	<table border="1"> <tr><td>Пол. контакта заземл.</td><td colspan="2">6 ч</td></tr> <tr><td>Номинальный ток (А)</td><td>16</td><td>32</td></tr> <tr><td>Полюсы</td><td colspan="2">5</td></tr> <tr><td>Размеры (мм)</td><td>a</td><td>b</td></tr> <tr><td></td><td>144</td><td>160</td></tr> <tr><td></td><td>80</td><td>80</td></tr> <tr><td></td><td>95.3</td><td>106.7</td></tr> <tr><td></td><td>129</td><td>144</td></tr> <tr><td></td><td>67.7</td><td>67.7</td></tr> <tr><td></td><td>87.5</td><td>101</td></tr> <tr><td>Номинальное сечение кабеля (мм²)</td><td>1-2.5</td><td>4-6</td></tr> </table>	Пол. контакта заземл.	6 ч		Номинальный ток (А)	16	32	Полюсы	5		Размеры (мм)	a	b		144	160		80	80		95.3	106.7		129	144		67.7	67.7		87.5	101	Номинальное сечение кабеля (мм²)	1-2.5	4-6															
Пол. контакта заземл.	6 ч																																																	
Номинальный ток (А)	16	32																																																
Полюсы	5																																																	
Размеры (мм)	a	b																																																
	144	160																																																
	80	80																																																
	95.3	106.7																																																
	129	144																																																
	67.7	67.7																																																
	87.5	101																																																
Номинальное сечение кабеля (мм²)	1-2.5	4-6																																																
	<p>УНТ-N1332 УНТ-N1432 Ток (А): 63А, 125А Напряжение (В): 220-250В~ 2P+E Класс защиты: IP67</p> 	<table border="1"> <tr><td>Пол. контакта заземл.</td><td colspan="2">6 ч</td></tr> <tr><td>Номинальный ток (А)</td><td>63</td><td>125</td></tr> <tr><td>Полюсы</td><td colspan="2">3</td></tr> <tr><td>Размеры (мм)</td><td>a</td><td>b</td></tr> <tr><td></td><td>171.3</td><td>262</td></tr> <tr><td></td><td>157</td><td>160</td></tr> <tr><td></td><td>169</td><td>202</td></tr> <tr><td></td><td>133.3</td><td>240</td></tr> <tr><td></td><td>108</td><td>140</td></tr> <tr><td></td><td>136</td><td>140</td></tr> <tr><td></td><td>8</td><td>8.1</td></tr> <tr><td></td><td>5</td><td>8</td></tr> <tr><td></td><td>216</td><td>286</td></tr> <tr><td></td><td>40</td><td>50</td></tr> <tr><td></td><td>M40</td><td>2x402x40</td></tr> <tr><td>Номинальное сечение кабеля (мм²)</td><td>6-25</td><td>16-50</td></tr> </table>	Пол. контакта заземл.	6 ч		Номинальный ток (А)	63	125	Полюсы	3		Размеры (мм)	a	b		171.3	262		157	160		169	202		133.3	240		108	140		136	140		8	8.1		5	8		216	286		40	50		M40	2x402x40	Номинальное сечение кабеля (мм²)	6-25	16-50
Пол. контакта заземл.	6 ч																																																	
Номинальный ток (А)	63	125																																																
Полюсы	3																																																	
Размеры (мм)	a	b																																																
	171.3	262																																																
	157	160																																																
	169	202																																																
	133.3	240																																																
	108	140																																																
	136	140																																																
	8	8.1																																																
	5	8																																																
	216	286																																																
	40	50																																																
	M40	2x402x40																																																
Номинальное сечение кабеля (мм²)	6-25	16-50																																																
	<p>УНТ-N1342 УНТ-N1442 Ток (А): 63А, 125А Напряжение (В): 380-415В~ 3P+E Класс защиты: IP67</p> 	<table border="1"> <tr><td>Пол. контакта заземл.</td><td colspan="2">6 ч</td></tr> <tr><td>Номинальный ток (А)</td><td>63</td><td>125</td></tr> <tr><td>Полюсы</td><td colspan="2">4</td></tr> <tr><td>Размеры (мм)</td><td>a</td><td>b</td></tr> <tr><td></td><td>171.3</td><td>262</td></tr> <tr><td></td><td>157</td><td>160</td></tr> <tr><td></td><td>169</td><td>202</td></tr> <tr><td></td><td>133.3</td><td>240</td></tr> <tr><td></td><td>108</td><td>140</td></tr> <tr><td></td><td>136</td><td>140</td></tr> <tr><td></td><td>8</td><td>8.1</td></tr> <tr><td></td><td>5</td><td>8</td></tr> <tr><td></td><td>216</td><td>286</td></tr> <tr><td></td><td>40</td><td>50</td></tr> <tr><td></td><td>M40</td><td>2x402x40</td></tr> <tr><td>Номинальное сечение кабеля (мм²)</td><td>6-25</td><td>16-50</td></tr> </table>	Пол. контакта заземл.	6 ч		Номинальный ток (А)	63	125	Полюсы	4		Размеры (мм)	a	b		171.3	262		157	160		169	202		133.3	240		108	140		136	140		8	8.1		5	8		216	286		40	50		M40	2x402x40	Номинальное сечение кабеля (мм²)	6-25	16-50
Пол. контакта заземл.	6 ч																																																	
Номинальный ток (А)	63	125																																																
Полюсы	4																																																	
Размеры (мм)	a	b																																																
	171.3	262																																																
	157	160																																																
	169	202																																																
	133.3	240																																																
	108	140																																																
	136	140																																																
	8	8.1																																																
	5	8																																																
	216	286																																																
	40	50																																																
	M40	2x402x40																																																
Номинальное сечение кабеля (мм²)	6-25	16-50																																																
	<p>УНТ-N1352 УНТ-N1452 Ток (А): 16А, 32А Напряжение (В): 220-380В~ 240-415В~ 3P+N+E Класс защиты: IP67</p> 	<table border="1"> <tr><td>Пол. контакта заземл.</td><td colspan="2">6 ч</td></tr> <tr><td>Номинальный ток (А)</td><td>63</td><td>125</td></tr> <tr><td>Полюсы</td><td colspan="2">4</td></tr> <tr><td>Размеры (мм)</td><td>a</td><td>b</td></tr> <tr><td></td><td>171.3</td><td>262</td></tr> <tr><td></td><td>157</td><td>160</td></tr> <tr><td></td><td>169</td><td>202</td></tr> <tr><td></td><td>133.3</td><td>240</td></tr> <tr><td></td><td>108</td><td>140</td></tr> <tr><td></td><td>136</td><td>140</td></tr> <tr><td></td><td>8</td><td>8.1</td></tr> <tr><td></td><td>5</td><td>8</td></tr> <tr><td></td><td>216</td><td>286</td></tr> <tr><td></td><td>40</td><td>50</td></tr> <tr><td></td><td>M40</td><td>2x402x40</td></tr> <tr><td>Номинальное сечение кабеля (мм²)</td><td>6-25</td><td>16-50</td></tr> </table>	Пол. контакта заземл.	6 ч		Номинальный ток (А)	63	125	Полюсы	4		Размеры (мм)	a	b		171.3	262		157	160		169	202		133.3	240		108	140		136	140		8	8.1		5	8		216	286		40	50		M40	2x402x40	Номинальное сечение кабеля (мм²)	6-25	16-50
Пол. контакта заземл.	6 ч																																																	
Номинальный ток (А)	63	125																																																
Полюсы	4																																																	
Размеры (мм)	a	b																																																
	171.3	262																																																
	157	160																																																
	169	202																																																
	133.3	240																																																
	108	140																																																
	136	140																																																
	8	8.1																																																
	5	8																																																
	216	286																																																
	40	50																																																
	M40	2x402x40																																																
Номинальное сечение кабеля (мм²)	6-25	16-50																																																
	<p>УНТ-N213-4 УНТ-N223-4 Ток (А): 16А, 32А Напряжение (В): 110-130В~ 2P+E Класс защиты: IP44</p> 	<table border="1"> <tr><td>Пол. контакта заземл.</td><td colspan="2">4 ч</td></tr> <tr><td>Номинальный ток (А)</td><td>16</td><td>32</td></tr> <tr><td>Полюсы</td><td colspan="2">3</td></tr> <tr><td>Размеры (мм)</td><td>a</td><td>b</td></tr> <tr><td></td><td>136</td><td>171</td></tr> <tr><td></td><td>61</td><td>75</td></tr> <tr><td></td><td>42.2</td><td>59</td></tr> <tr><td></td><td>72</td><td>88.6</td></tr> <tr><td></td><td>52.2</td><td>67.4</td></tr> <tr><td></td><td>72</td><td>88.6</td></tr> <tr><td></td><td>27.2</td><td>34.5</td></tr> <tr><td>Номинальное сечение кабеля (мм²)</td><td>1-2.5</td><td>2.5-6</td></tr> </table>	Пол. контакта заземл.	4 ч		Номинальный ток (А)	16	32	Полюсы	3		Размеры (мм)	a	b		136	171		61	75		42.2	59		72	88.6		52.2	67.4		72	88.6		27.2	34.5	Номинальное сечение кабеля (мм²)	1-2.5	2.5-6												
Пол. контакта заземл.	4 ч																																																	
Номинальный ток (А)	16	32																																																
Полюсы	3																																																	
Размеры (мм)	a	b																																																
	136	171																																																
	61	75																																																
	42.2	59																																																
	72	88.6																																																
	52.2	67.4																																																
	72	88.6																																																
	27.2	34.5																																																
Номинальное сечение кабеля (мм²)	1-2.5	2.5-6																																																
	<p>УНТ-N213 УНТ-N223 Ток (А): 16А, 32А Напряжение (В): 220-240В~ 2P+E Класс защиты: IP44</p> 	<table border="1"> <tr><td>Пол. контакта заземл.</td><td colspan="2">6 ч</td></tr> <tr><td>Номинальный ток (А)</td><td>16</td><td>32</td></tr> <tr><td>Полюсы</td><td colspan="2">3</td></tr> <tr><td>Размеры (мм)</td><td>a</td><td>b</td></tr> <tr><td></td><td>136</td><td>171</td></tr> <tr><td></td><td>61</td><td>75</td></tr> <tr><td></td><td>42.2</td><td>59</td></tr> <tr><td></td><td>72</td><td>88.6</td></tr> <tr><td></td><td>52.2</td><td>67.4</td></tr> <tr><td></td><td>72</td><td>88.6</td></tr> <tr><td></td><td>27.2</td><td>34.5</td></tr> <tr><td>Номинальное сечение кабеля (мм²)</td><td>1-2.5</td><td>2.5-6</td></tr> </table>	Пол. контакта заземл.	6 ч		Номинальный ток (А)	16	32	Полюсы	3		Размеры (мм)	a	b		136	171		61	75		42.2	59		72	88.6		52.2	67.4		72	88.6		27.2	34.5	Номинальное сечение кабеля (мм²)	1-2.5	2.5-6												
Пол. контакта заземл.	6 ч																																																	
Номинальный ток (А)	16	32																																																
Полюсы	3																																																	
Размеры (мм)	a	b																																																
	136	171																																																
	61	75																																																
	42.2	59																																																
	72	88.6																																																
	52.2	67.4																																																
	72	88.6																																																
	27.2	34.5																																																
Номинальное сечение кабеля (мм²)	1-2.5	2.5-6																																																

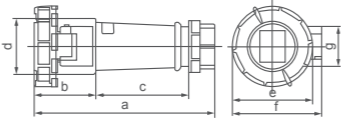

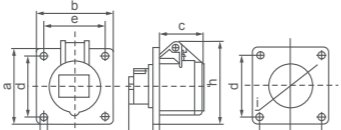

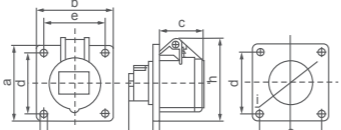

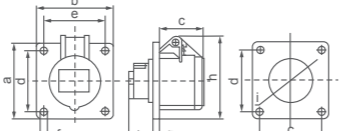

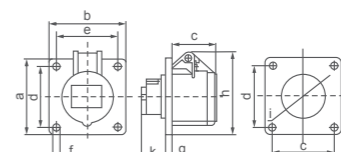

Монтируемые штепсельные соединения УНТ-N

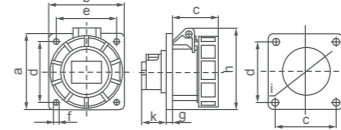
	<p>УНТ-N214 УНТ-N224 Ток (А): 16А, 32А Напряжение (В): 380-415В~ 3P+E Класс защиты: IP44</p> 	<table border="1"> <tr><td>Пол. контакта заземл.</td><td colspan="2">6 ч</td></tr> <tr><td>Номинальный ток (А)</td><td>16</td><td>32</td></tr> <tr><td>Полюсы</td><td colspan="2">4</td></tr> <tr><td>Размеры (мм)</td><td>a</td><td>b</td></tr> <tr><td></td><td>142.5</td><td>171</td></tr> <tr><td></td><td>62</td><td>75</td></tr> <tr><td></td><td>47.5</td><td>59</td></tr> <tr><td></td><td>77</td><td>88.6</td></tr> <tr><td></td><td>58.6</td><td>67.4</td></tr> <tr><td></td><td>77</td><td>88.6</td></tr> <tr><td></td><td>27.2</td><td>34.5</td></tr> <tr><td>Номинальное сечение кабеля (мм²)</td><td>1-2.5</td><td>2.5-6</td></tr> </table>	Пол. контакта заземл.	6 ч		Номинальный ток (А)	16	32	Полюсы	4		Размеры (мм)	a	b		142.5	171		62	75		47.5	59		77	88.6		58.6	67.4		77	88.6		27.2	34.5	Номинальное сечение кабеля (мм²)	1-2.5	2.5-6
Пол. контакта заземл.	6 ч																																					
Номинальный ток (А)	16	32																																				
Полюсы	4																																					
Размеры (мм)	a	b																																				
	142.5	171																																				
	62	75																																				
	47.5	59																																				
	77	88.6																																				
	58.6	67.4																																				
	77	88.6																																				
	27.2	34.5																																				
Номинальное сечение кабеля (мм²)	1-2.5	2.5-6																																				
	<p>УНТ-N215 УНТ-N225 Ток (А): 16А, 32А Напряжение (В): 220-380В~, 240-415В~ 3P+N+E Класс защиты: IP44</p> 	<table border="1"> <tr><td>Пол. контакта заземл.</td><td colspan="2">6 ч</td></tr> <tr><td>Номинальный ток (А)</td><td>16</td><td>32</td></tr> <tr><td>Полюсы</td><td colspan="2">5</td></tr> <tr><td>Размеры (мм)</td><td>a</td><td>b</td></tr> <tr><td></td><td>150</td><td>176</td></tr> <tr><td></td><td>62</td><td>75</td></tr> <tr><td></td><td>55</td><td>64</td></tr> <tr><td></td><td>82.5</td><td>100.2</td></tr> <tr><td></td><td>65.3</td><td>73.5</td></tr> <tr><td></td><td>82.5</td><td>100.2</td></tr> <tr><td></td><td>27.2</td><td>34.5</td></tr> <tr><td>Номинальное сечение кабеля (мм²)</td><td>1-2.5</td><td>2.5-6</td></tr> </table>	Пол. контакта заземл.	6 ч		Номинальный ток (А)	16	32	Полюсы	5		Размеры (мм)	a	b		150	176		62	75		55	64		82.5	100.2		65.3	73.5		82.5	100.2		27.2	34.5	Номинальное сечение кабеля (мм²)	1-2.5	2.5-6
Пол. контакта заземл.	6 ч																																					
Номинальный ток (А)	16	32																																				
Полюсы	5																																					
Размеры (мм)	a	b																																				
	150	176																																				
	62	75																																				
	55	64																																				
	82.5	100.2																																				
	65.3	73.5																																				
	82.5	100.2																																				
	27.2	34.5																																				
Номинальное сечение кабеля (мм²)	1-2.5	2.5-6																																				
	<p>УНТ-N2132-4 УНТ-N2232-4 Ток (А): 16А, 32А Напряжение (В): 110-130В~ 2P+E Класс защиты: IP67</p> 	<table border="1"> <tr><td>Пол. контакта заземл.</td><td colspan="2">4 ч</td></tr> <tr><td>Номинальный ток (А)</td><td>16</td><td>32</td></tr> <tr><td>Полюсы</td><td colspan="2">3</td></tr> <tr><td>Размеры (мм)</td><td>a</td><td>b</td></tr> <tr><td></td><td>139</td><td>172.8</td></tr> <tr><td></td><td>63.5</td><td>76.8</td></tr> <tr><td></td><td>42.2</td><td>59</td></tr> <tr><td></td><td>71.5</td><td>87.5</td></tr> <tr><td></td><td>71.5</td><td>93</td></tr> <tr><td></td><td>79.2</td><td>96.5</td></tr> <tr><td></td><td>27.2</td><td>34.5</td></tr> <tr><td>Номинальное сечение кабеля (мм²)</td><td>1-2.5</td><td>2.5-6</td></tr> </table>	Пол. контакта заземл.	4 ч		Номинальный ток (А)	16	32	Полюсы	3		Размеры (мм)	a	b		139	172.8		63.5	76.8		42.2	59		71.5	87.5		71.5	93		79.2	96.5		27.2	34.5	Номинальное сечение кабеля (мм²)	1-2.5	2.5-6
Пол. контакта заземл.	4 ч																																					
Номинальный ток (А)	16	32																																				
Полюсы	3																																					
Размеры (мм)	a	b																																				
	139	172.8																																				
	63.5	76.8																																				
	42.2	59																																				
	71.5	87.5																																				
	71.5	93																																				
	79.2	96.5																																				
	27.2	34.5																																				
Номинальное сечение кабеля (мм²)	1-2.5	2.5-6																																				
	<p>УНТ-N2132 УНТ-N2232 Ток (А): 16А, 32А Напряжение (В): 220-240В~ 2P+E Класс защиты: IP67</p> 	<table border="1"> <tr><td>Пол. контакта заземл.</td><td colspan="2">6 ч</td></tr> <tr><td>Номинальный ток (А)</td><td>16</td><td>32</td></tr> <tr><td>Полюсы</td><td colspan="2">3</td></tr> <tr><td>Размеры (мм)</td><td>a</td><td>b</td></tr> <tr><td></td><td>139</td><td>172.8</td></tr> <tr><td></td><td>63.5</td><td>76.8</td></tr> <tr><td></td><td>42.2</td><td>59</td></tr> <tr><td></td><td>71.5</td><td>87.5</td></tr> <tr><td></td><td>71.5</td><td>93</td></tr> <tr><td></td><td>79.2</td><td>96.5</td></tr> <tr><td></td><td>27.2</td><td>34.5</td></tr> <tr><td>Номинальное сечение кабеля (мм²)</td><td>1-2.5</td><td>2.5-6</td></tr> </table>	Пол. контакта заземл.	6 ч		Номинальный ток (А)	16	32	Полюсы	3		Размеры (мм)	a	b		139	172.8		63.5	76.8		42.2	59		71.5	87.5		71.5	93		79.2	96.5		27.2	34.5	Номинальное сечение кабеля (мм²)	1-2.5	2.5-6
Пол. контакта заземл.	6 ч																																					
Номинальный ток (А)	16	32																																				
Полюсы	3																																					
Размеры (мм)	a	b																																				
	139	172.8																																				
	63.5	76.8																																				
	42.2	59																																				
	71.5	87.5																																				
	71.5	93																																				
	79.2	96.5																																				
	27.2	34.5																																				
Номинальное сечение кабеля (мм²)	1-2.5	2.5-6																																				
	<p>УНТ-N2142 УНТ-N2242 Ток (А): 16А, 32А Напряжение (В): 380-415В~ 3P+E Класс защиты: IP67</p> 	<table border="1"> <tr><td>Пол. контакта заземл.</td><td colspan="2">6 ч</td></tr> <tr><td>Номинальный ток (А)</td><td>16</td><td>32</td></tr> <tr><td>Полюсы</td><td colspan="2">4</td></tr> <tr><td>Размеры (мм)</td><td>a</td><td>b</td></tr> <tr><td></td><td>145</td><td>172.8</td></tr> <tr><td></td><td>64.5</td><td>76.8</td></tr> <tr><td></td><td>47.5</td><td>59</td></tr> <tr><td></td><td>77</td><td>87.5</td></tr> <tr><td></td><td>79</td><td>93</td></tr> <tr><td></td><td>85</td><td>96.5</td></tr> <tr><td></td><td>27.2</td><td>34.5</td></tr> <tr><td>Номинальное сечение кабеля (мм²)</td><td>1-2.5</td><td>2.5-6</td></tr> </table>	Пол. контакта заземл.	6 ч		Номинальный ток (А)	16	32	Полюсы	4		Размеры (мм)	a	b		145	172.8		64.5	76.8		47.5	59		77	87.5		79	93		85	96.5		27.2	34.5	Номинальное сечение кабеля (мм²)	1-2.5	2.5-6
Пол. контакта заземл.	6 ч																																					
Номинальный ток (А)	16	32																																				
Полюсы	4																																					
Размеры (мм)	a	b																																				
	145	172.8																																				
	64.5	76.8																																				
	47.5	59																																				
	77	87.5																																				
	79	93																																				
	85	96.5																																				
	27.2	34.5																																				
Номинальное сечение кабеля (мм²)	1-2.5	2.5-6																																				
	<p>УНТ-N2152 УНТ-N2252 Ток (А): 16А, 32А Напряжение (В): 220-380В~ 240-415В~ 3P+N+E Класс защиты: IP67</p> 	<table border="1"> <tr><td>Пол. контакта заземл.</td><td colspan="2">6 ч</td></tr> <tr><td>Номинальный ток (А)</td><td>16</td><td>32</td></tr> <tr><td>Полюсы</td><td colspan="2">5</td></tr> <tr><td>Размеры (мм)</td><td>a</td><td>b</td></tr> <tr><td></td><td>152</td><td>178.5</td></tr> <tr><td></td><td>64.5</td><td>77.5</td></tr> <tr><td></td><td>55</td><td>64</td></tr> <tr><td></td><td>84</td><td>99</td></tr> <tr><td></td><td>87.5</td><td>101</td></tr> <tr><td></td><td>91</td><td>108.5</td></tr> <tr><td></td><td>27.2</td><td>34.5</td></tr> <tr><td>Номинальное сечение кабеля (мм²)</td><td>1-2.5</td><td>2.5-6</td></tr> </table>	Пол. контакта заземл.	6 ч		Номинальный ток (А)	16	32	Полюсы	5		Размеры (мм)	a	b		152	178.5		64.5	77.5		55	64		84	99		87.5	101		91	108.5		27.2	34.5	Номинальное сечение кабеля (мм²)	1-2.5	2.5-6
Пол. контакта заземл.	6 ч																																					
Номинальный ток (А)	16	32																																				
Полюсы	5																																					
Размеры (мм)	a	b																																				
	152	178.5																																				
	64.5	77.5																																				
	55	64																																				
	84	99																																				
	87.5	101																																				
	91	108.5																																				
	27.2	34.5																																				
Номинальное сечение кабеля (мм²)	1-2.5	2.5-6																																				

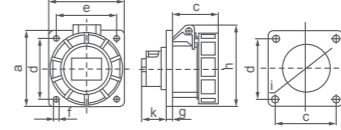
Монтируемые штепсельные соединения **УНТ-N**

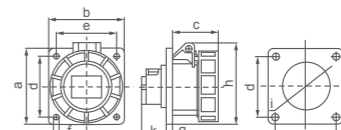
	<p>УНТ-N2332 УНТ-N2432 Ток (А): 63А, 125А Напряжение (В): 220-250В~ 2P+E Класс защиты: IP67</p>		<table border="1"> <tr><td colspan="2">Пол. контакта заземл.</td><td colspan="2">6 ч</td></tr> <tr><td colspan="2">Номинальный ток (А)</td><td>63</td><td>125</td></tr> <tr><td colspan="2">Полюсы</td><td colspan="2">3</td></tr> <tr><td colspan="2">Размеры (мм)</td><td>a</td><td>260</td><td>300</td></tr> <tr><td colspan="2"></td><td>b</td><td>104</td><td>140</td></tr> <tr><td colspan="2"></td><td>c</td><td>95.8</td><td>100</td></tr> <tr><td colspan="2"></td><td>d</td><td>77.4</td><td>89.5</td></tr> <tr><td colspan="2"></td><td>e</td><td>112.5</td><td>121</td></tr> <tr><td colspan="2"></td><td>f</td><td>109</td><td>125</td></tr> <tr><td colspan="2"></td><td>g</td><td>24</td><td>34.5</td></tr> <tr><td colspan="2">Номинальное сечение кабеля (мм²)</td><td>6-16</td><td>16-50</td></tr> </table>	Пол. контакта заземл.		6 ч		Номинальный ток (А)		63	125	Полюсы		3		Размеры (мм)		a	260	300			b	104	140			c	95.8	100			d	77.4	89.5			e	112.5	121			f	109	125			g	24	34.5	Номинальное сечение кабеля (мм²)		6-16	16-50															
Пол. контакта заземл.		6 ч																																																																			
Номинальный ток (А)		63	125																																																																		
Полюсы		3																																																																			
Размеры (мм)		a	260	300																																																																	
		b	104	140																																																																	
		c	95.8	100																																																																	
		d	77.4	89.5																																																																	
		e	112.5	121																																																																	
		f	109	125																																																																	
		g	24	34.5																																																																	
Номинальное сечение кабеля (мм²)		6-16	16-50																																																																		
	<p>УНТ-N2342 УНТ-N2442 Ток (А): 63А, 125А Напряжение (В): 380-415В~ 3P+E Класс защиты: IP67</p>		<table border="1"> <tr><td colspan="2">Пол. контакта заземл.</td><td colspan="2">6 ч</td></tr> <tr><td colspan="2">Номинальный ток (А)</td><td>63</td><td>125</td></tr> <tr><td colspan="2">Полюсы</td><td colspan="2">4</td></tr> <tr><td colspan="2">Размеры (мм)</td><td>a</td><td>260</td><td>300</td></tr> <tr><td colspan="2"></td><td>b</td><td>104</td><td>140</td></tr> <tr><td colspan="2"></td><td>c</td><td>95.8</td><td>100</td></tr> <tr><td colspan="2"></td><td>d</td><td>77.4</td><td>89.5</td></tr> <tr><td colspan="2"></td><td>e</td><td>112.5</td><td>121</td></tr> <tr><td colspan="2"></td><td>f</td><td>109</td><td>125</td></tr> <tr><td colspan="2"></td><td>g</td><td>24</td><td>34.5</td></tr> <tr><td colspan="2">Номинальное сечение кабеля (мм²)</td><td>6-16</td><td>16-50</td></tr> </table>	Пол. контакта заземл.		6 ч		Номинальный ток (А)		63	125	Полюсы		4		Размеры (мм)		a	260	300			b	104	140			c	95.8	100			d	77.4	89.5			e	112.5	121			f	109	125			g	24	34.5	Номинальное сечение кабеля (мм²)		6-16	16-50															
Пол. контакта заземл.		6 ч																																																																			
Номинальный ток (А)		63	125																																																																		
Полюсы		4																																																																			
Размеры (мм)		a	260	300																																																																	
		b	104	140																																																																	
		c	95.8	100																																																																	
		d	77.4	89.5																																																																	
		e	112.5	121																																																																	
		f	109	125																																																																	
		g	24	34.5																																																																	
Номинальное сечение кабеля (мм²)		6-16	16-50																																																																		
	<p>УНТ-N2352 УНТ-N2452 Ток (А): 16А, 32А Напряжение (В): 220-380В~, 240-415В~ 3P+N+E Класс защиты: IP67</p>		<table border="1"> <tr><td colspan="2">Пол. контакта заземл.</td><td colspan="2">6 ч</td></tr> <tr><td colspan="2">Номинальный ток (А)</td><td>63</td><td>125</td></tr> <tr><td colspan="2">Полюсы</td><td colspan="2">5</td></tr> <tr><td colspan="2">Размеры (мм)</td><td>a</td><td>260</td><td>300</td></tr> <tr><td colspan="2"></td><td>b</td><td>104</td><td>140</td></tr> <tr><td colspan="2"></td><td>c</td><td>95.8</td><td>100</td></tr> <tr><td colspan="2"></td><td>d</td><td>77.4</td><td>89.5</td></tr> <tr><td colspan="2"></td><td>e</td><td>112.5</td><td>121</td></tr> <tr><td colspan="2"></td><td>f</td><td>109</td><td>125</td></tr> <tr><td colspan="2"></td><td>g</td><td>24</td><td>34.5</td></tr> <tr><td colspan="2">Номинальное сечение кабеля (мм²)</td><td>6-16</td><td>16-50</td></tr> </table>	Пол. контакта заземл.		6 ч		Номинальный ток (А)		63	125	Полюсы		5		Размеры (мм)		a	260	300			b	104	140			c	95.8	100			d	77.4	89.5			e	112.5	121			f	109	125			g	24	34.5	Номинальное сечение кабеля (мм²)		6-16	16-50															
Пол. контакта заземл.		6 ч																																																																			
Номинальный ток (А)		63	125																																																																		
Полюсы		5																																																																			
Размеры (мм)		a	260	300																																																																	
		b	104	140																																																																	
		c	95.8	100																																																																	
		d	77.4	89.5																																																																	
		e	112.5	121																																																																	
		f	109	125																																																																	
		g	24	34.5																																																																	
Номинальное сечение кабеля (мм²)		6-16	16-50																																																																		
	<p>УНТ-N313-4 УНТ-N323-4 Ток (А): 16А, 32А Напряжение (В): 110-130В~ 2P+E Класс защиты: IP44</p>		<table border="1"> <tr><td colspan="2">Пол. контакта заземл.</td><td colspan="2">4 ч</td></tr> <tr><td colspan="2">Номинальный ток (А)</td><td>16</td><td>32</td></tr> <tr><td colspan="2">Полюсы</td><td colspan="2">3</td></tr> <tr><td colspan="2">Размеры (мм)</td><td>a</td><td>75</td><td>75</td></tr> <tr><td colspan="2"></td><td>b</td><td>75</td><td>75</td></tr> <tr><td colspan="2"></td><td>c</td><td>43.2</td><td>62.2</td></tr> <tr><td colspan="2"></td><td>d</td><td>60</td><td>60</td></tr> <tr><td colspan="2"></td><td>e</td><td>60</td><td>60</td></tr> <tr><td colspan="2"></td><td>f</td><td>5.5</td><td>5.5</td></tr> <tr><td colspan="2"></td><td>g</td><td>6</td><td>6</td></tr> <tr><td colspan="2"></td><td>h</td><td>81</td><td>88.6</td></tr> <tr><td colspan="2"></td><td>k</td><td>23</td><td>25</td></tr> <tr><td colspan="2"></td><td>l</td><td>42</td><td>56</td></tr> <tr><td colspan="2">Номинальное сечение кабеля (мм²)</td><td>1-2.5</td><td>2.5-6</td></tr> </table>	Пол. контакта заземл.		4 ч		Номинальный ток (А)		16	32	Полюсы		3		Размеры (мм)		a	75	75			b	75	75			c	43.2	62.2			d	60	60			e	60	60			f	5.5	5.5			g	6	6			h	81	88.6			k	23	25			l	42	56	Номинальное сечение кабеля (мм²)		1-2.5	2.5-6
Пол. контакта заземл.		4 ч																																																																			
Номинальный ток (А)		16	32																																																																		
Полюсы		3																																																																			
Размеры (мм)		a	75	75																																																																	
		b	75	75																																																																	
		c	43.2	62.2																																																																	
		d	60	60																																																																	
		e	60	60																																																																	
		f	5.5	5.5																																																																	
		g	6	6																																																																	
		h	81	88.6																																																																	
		k	23	25																																																																	
		l	42	56																																																																	
Номинальное сечение кабеля (мм²)		1-2.5	2.5-6																																																																		
	<p>УНТ-N313 УНТ-N323 Ток (А): 16А, 32А Напряжение(В): 220-240В~ 2P+E Класс защиты: IP44</p>		<table border="1"> <tr><td colspan="2">Пол. контакта заземл.</td><td colspan="2">6 ч</td></tr> <tr><td colspan="2">Номинальный ток (А)</td><td>16</td><td>32</td></tr> <tr><td colspan="2">Полюсы</td><td colspan="2">3</td></tr> <tr><td colspan="2">Размеры (мм)</td><td>a</td><td>75</td><td>75</td></tr> <tr><td colspan="2"></td><td>b</td><td>75</td><td>75</td></tr> <tr><td colspan="2"></td><td>c</td><td>43.2</td><td>62.2</td></tr> <tr><td colspan="2"></td><td>d</td><td>60</td><td>60</td></tr> <tr><td colspan="2"></td><td>e</td><td>60</td><td>60</td></tr> <tr><td colspan="2"></td><td>f</td><td>5.5</td><td>5.5</td></tr> <tr><td colspan="2"></td><td>g</td><td>6</td><td>6</td></tr> <tr><td colspan="2"></td><td>h</td><td>81</td><td>88.6</td></tr> <tr><td colspan="2"></td><td>k</td><td>23</td><td>25</td></tr> <tr><td colspan="2"></td><td>l</td><td>42</td><td>56</td></tr> <tr><td colspan="2">Номинальное сечение кабеля (мм²)</td><td>1-2.5</td><td>2.5-6</td></tr> </table>	Пол. контакта заземл.		6 ч		Номинальный ток (А)		16	32	Полюсы		3		Размеры (мм)		a	75	75			b	75	75			c	43.2	62.2			d	60	60			e	60	60			f	5.5	5.5			g	6	6			h	81	88.6			k	23	25			l	42	56	Номинальное сечение кабеля (мм²)		1-2.5	2.5-6
Пол. контакта заземл.		6 ч																																																																			
Номинальный ток (А)		16	32																																																																		
Полюсы		3																																																																			
Размеры (мм)		a	75	75																																																																	
		b	75	75																																																																	
		c	43.2	62.2																																																																	
		d	60	60																																																																	
		e	60	60																																																																	
		f	5.5	5.5																																																																	
		g	6	6																																																																	
		h	81	88.6																																																																	
		k	23	25																																																																	
		l	42	56																																																																	
Номинальное сечение кабеля (мм²)		1-2.5	2.5-6																																																																		
	<p>УНТ-N314 УНТ-N324 Ток (А): 16А, 32А Напряжение (В): 380-415В~ 3P+E Класс защиты: IP44</p>		<table border="1"> <tr><td colspan="2">Пол. контакта заземл.</td><td colspan="2">6 ч</td></tr> <tr><td colspan="2">Номинальный ток (А)</td><td>16</td><td>32</td></tr> <tr><td colspan="2">Полюсы</td><td colspan="2">4</td></tr> <tr><td colspan="2">Размеры (мм)</td><td>a</td><td>75</td><td>75</td></tr> <tr><td colspan="2"></td><td>b</td><td>75</td><td>75</td></tr> <tr><td colspan="2"></td><td>c</td><td>45.2</td><td>62.2</td></tr> <tr><td colspan="2"></td><td>d</td><td>60</td><td>60</td></tr> <tr><td colspan="2"></td><td>e</td><td>60</td><td>60</td></tr> <tr><td colspan="2"></td><td>f</td><td>5.5</td><td>5.5</td></tr> <tr><td colspan="2"></td><td>g</td><td>6</td><td>6</td></tr> <tr><td colspan="2"></td><td>h</td><td>83</td><td>88.6</td></tr> <tr><td colspan="2"></td><td>k</td><td>23</td><td>25</td></tr> <tr><td colspan="2"></td><td>l</td><td>48</td><td>56</td></tr> <tr><td colspan="2">Номинальное сечение кабеля (мм²)</td><td>1-2.5</td><td>2.5-6</td></tr> </table>	Пол. контакта заземл.		6 ч		Номинальный ток (А)		16	32	Полюсы		4		Размеры (мм)		a	75	75			b	75	75			c	45.2	62.2			d	60	60			e	60	60			f	5.5	5.5			g	6	6			h	83	88.6			k	23	25			l	48	56	Номинальное сечение кабеля (мм²)		1-2.5	2.5-6
Пол. контакта заземл.		6 ч																																																																			
Номинальный ток (А)		16	32																																																																		
Полюсы		4																																																																			
Размеры (мм)		a	75	75																																																																	
		b	75	75																																																																	
		c	45.2	62.2																																																																	
		d	60	60																																																																	
		e	60	60																																																																	
		f	5.5	5.5																																																																	
		g	6	6																																																																	
		h	83	88.6																																																																	
		k	23	25																																																																	
		l	48	56																																																																	
Номинальное сечение кабеля (мм²)		1-2.5	2.5-6																																																																		

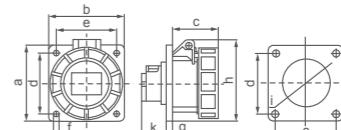
Монтируемые штепсельные соединения **УНТ-N**

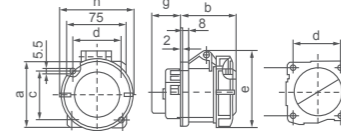
	<p>УНТ-N315 УНТ-N325 Ток (А): 16А, 32А Напряжение (В): 220-380В~, 240-415В~ 3P+N+E Класс защиты: IP44</p>		<table border="1"> <tr><td colspan="2">Пол. контакта заземл.</td><td colspan="2">6 ч</td></tr> <tr><td colspan="2">Номинальный ток (А)</td><td>16</td><td>32</td></tr> <tr><td colspan="2">Полюсы</td><td colspan="2">4</td></tr> <tr><td colspan="2">Размеры (мм)</td><td>a</td><td>75</td><td>75</td></tr> <tr><td colspan="2"></td><td>b</td><td>75</td><td>75</td></tr> <tr><td colspan="2"></td><td>c</td><td>51.2</td><td>67</td></tr> <tr><td colspan="2"></td><td>d</td><td>60</td><td>60</td></tr> <tr><td colspan="2"></td><td>e</td><td>60</td><td>60</td></tr> <tr><td colspan="2"></td><td>f</td><td>5.5</td><td>5.5</td></tr> <tr><td colspan="2"></td><td>g</td><td>6</td><td>6</td></tr> <tr><td colspan="2"></td><td>h</td><td>83</td><td>100.2</td></tr> <tr><td colspan="2"></td><td>k</td><td>23</td><td>25</td></tr> <tr><td colspan="2"></td><td>l</td><td>55</td><td>61.5</td></tr> <tr><td colspan="2">Номинальное сечение кабеля (мм²)</td><td>1-2.5</td><td>2.5-6</td></tr> </table>	Пол. контакта заземл.		6 ч		Номинальный ток (А)		16	32	Полюсы		4		Размеры (мм)		a	75	75			b	75	75			c	51.2	67			d	60	60			e	60	60			f	5.5	5.5			g	6	6			h	83	100.2			k	23	25			l	55	61.5	Номинальное сечение кабеля (мм²)		1-2.5	2.5-6
Пол. контакта заземл.		6 ч																																																																			
Номинальный ток (А)		16	32																																																																		
Полюсы		4																																																																			
Размеры (мм)		a	75	75																																																																	
		b	75	75																																																																	
		c	51.2	67																																																																	
		d	60	60																																																																	
		e	60	60																																																																	
		f	5.5	5.5																																																																	
		g	6	6																																																																	
		h	83	100.2																																																																	
		k	23	25																																																																	
		l	55	61.5																																																																	
Номинальное сечение кабеля (мм²)		1-2.5	2.5-6																																																																		
	<p>УНТ-N3132-4 УНТ-N3232-4 Ток (А): 16А, 32А Напряжение (В): 110-130В~ 2P+E Класс защиты: IP67</p>		<table border="1"> <tr><td colspan="2">Пол. контакта заземл.</td><td colspan="2">6 ч</td></tr> <tr><td colspan="2">Номинальный ток (А)</td><td>16</td><td>32</td></tr> <tr><td colspan="2">Полюсы</td><td colspan="2">3</td></tr> <tr><td colspan="2">Размеры (мм)</td><td>a</td><td>75</td><td>75</td></tr> <tr><td colspan="2"></td><td>b</td><td>75</td><td>75</td></tr> <tr><td colspan="2"></td><td>c</td><td>46.1</td><td>57.7</td></tr> <tr><td colspan="2"></td><td>d</td><td>60</td><td>60</td></tr> <tr><td colspan="2"></td><td>e</td><td>60</td><td>60</td></tr> <tr><td colspan="2"></td><td>f</td><td>5.5</td><td>5.5</td></tr> <tr><td colspan="2"></td><td>g</td><td>6</td><td>6</td></tr> <tr><td colspan="2"></td><td>h</td><td>83</td><td>96.5</td></tr> <tr><td colspan="2"></td><td>k</td><td>23</td><td>25</td></tr> <tr><td colspan="2"></td><td>l</td><td>55</td><td>56</td></tr> <tr><td colspan="2">Номинальное сечение кабеля (мм²)</td><td>1-2.5</td><td>2.5-6</td></tr> </table>	Пол. контакта заземл.		6 ч		Номинальный ток (А)		16	32	Полюсы		3		Размеры (мм)		a	75	75			b	75	75			c	46.1	57.7			d	60	60			e	60	60			f	5.5	5.5			g	6	6			h	83	96.5			k	23	25			l	55	56	Номинальное сечение кабеля (мм²)		1-2.5	2.5-6
Пол. контакта заземл.		6 ч																																																																			
Номинальный ток (А)		16	32																																																																		
Полюсы		3																																																																			
Размеры (мм)		a	75	75																																																																	
		b	75	75																																																																	
		c	46.1	57.7																																																																	
		d	60	60																																																																	
		e	60	60																																																																	
		f	5.5	5.5																																																																	
		g	6	6																																																																	
		h	83	96.5																																																																	
		k	23	25																																																																	
		l	55	56																																																																	
Номинальное сечение кабеля (мм²)		1-2.5	2.5-6																																																																		
	<p>УНТ-N3132 УНТ-N3232 Ток (А): 16А, 32А Напряжение (В): 220-240В~ 2P+E Класс защиты: IP67</p>		<table border="1"> <tr><td colspan="2">Пол. контакта заземл.</td><td colspan="2">6 ч</td></tr> <tr><td colspan="2">Номинальный ток (А)</td><td>16</td><td>32</td></tr> <tr><td colspan="2">Полюсы</td><td colspan="2">3</td></tr> <tr><td colspan="2">Размеры (мм)</td><td>a</td><td>75</td><td>75</td></tr> <tr><td colspan="2"></td><td>b</td><td>75</td><td>75</td></tr> <tr><td colspan="2"></td><td>c</td><td>46.1</td><td>57.7</td></tr> <tr><td colspan="2"></td><td>d</td><td>60</td><td>60</td></tr> <tr><td colspan="2"></td><td>e</td><td>60</td><td>60</td></tr> <tr><td colspan="2"></td><td>f</td><td>5.5</td><td>5.5</td></tr> <tr><td colspan="2"></td><td>g</td><td>6</td><td>6</td></tr> <tr><td colspan="2"></td><td>h</td><td>83</td><td>96.5</td></tr> <tr><td colspan="2"></td><td>k</td><td>23</td><td>25</td></tr> <tr><td colspan="2"></td><td>l</td><td>42</td><td>56</td></tr> <tr><td colspan="2">Номинальное сечение кабеля (мм²)</td><td>1-2.5</td><td>2.5-6</td></tr> </table>	Пол. контакта заземл.		6 ч		Номинальный ток (А)		16	32	Полюсы		3		Размеры (мм)		a	75	75			b	75	75			c	46.1	57.7			d	60	60			e	60	60			f	5.5	5.5			g	6	6			h	83	96.5			k	23	25			l	42	56	Номинальное сечение кабеля (мм²)		1-2.5	2.5-6
Пол. контакта заземл.		6 ч																																																																			
Номинальный ток (А)		16	32																																																																		
Полюсы		3																																																																			
Размеры (мм)		a	75	75																																																																	
		b	75	75																																																																	
		c	46.1	57.7																																																																	
		d	60	60																																																																	
		e	60	60																																																																	
		f	5.5	5.5																																																																	
		g	6	6																																																																	
		h	83	96.5																																																																	
		k	23	25																																																																	
		l	42	56																																																																	
Номинальное сечение кабеля (мм²)		1-2.5	2.5-6																																																																		
	<p>УНТ-N3142 УНТ-N3242 Ток (А): 16А, 32А Напряжение (В): 380-415В~ 3P+E Класс защиты: IP67</p>		<table border="1"> <tr><td colspan="2">Пол. контакта заземл.</td><td colspan="2">6 ч</td></tr> <tr><td colspan="2">Номинальный ток (А)</td><td>16</td><td>32</td></tr> <tr><td colspan="2">Полюсы</td><td colspan="2">4</td></tr> <tr><td colspan="2">Размеры (мм)</td><td>a</td><td>75</td><td>75</td></tr> <tr><td colspan="2"></td><td>b</td><td>75</td><td>75</td></tr> <tr><td colspan="2"></td><td>c</td><td>47.7</td><td>57.7</td></tr> <tr><td colspan="2"></td><td>d</td><td>60</td><td>60</td></tr> <tr><td colspan="2"></td><td>e</td><td>60</td><td>60</td></tr> <tr><td colspan="2"></td><td>f</td><td>5.5</td><td>5.5</td></tr> <tr><td colspan="2"></td><td>g</td><td>6</td><td>6</td></tr> <tr><td colspan="2"></td><td>h</td><td>85</td><td>96.5</td></tr> <tr><td colspan="2"></td><td>k</td><td>23</td><td>25</td></tr> <tr><td colspan="2"></td><td>l</td><td>48</td><td>56</td></tr> <tr><td colspan="2">Номинальное сечение кабеля (мм²)</td><td>1-2.5</td><td>2.5-6</td></tr> </table>	Пол. контакта заземл.		6 ч		Номинальный ток (А)		16	32	Полюсы		4		Размеры (мм)		a	75	75			b	75	75			c	47.7	57.7			d	60	60			e	60	60			f	5.5	5.5			g	6	6			h	85	96.5			k	23	25			l	48	56	Номинальное сечение кабеля (мм²)		1-2.5	2.5-6
Пол. контакта заземл.		6 ч																																																																			
Номинальный ток (А)		16	32																																																																		
Полюсы		4																																																																			
Размеры (мм)		a	75	75																																																																	
		b	75	75																																																																	
		c	47.7	57.7																																																																	
		d	60	60																																																																	
		e	60	60																																																																	
		f	5.5	5.5																																																																	
		g	6	6																																																																	
		h	85	96.5																																																																	
		k	23	25																																																																	
		l	48	56																																																																	
Номинальное сечение кабеля (мм²)		1-2.5	2.5-6																																																																		
	<p>УНТ-N3152 УНТ-N3252 Ток (А): 16А, 32А Напряжение (В): 220-380В~, 240-415В~ 3P+N+E Класс защиты: IP67</p>		<table border="1"> <tr><td colspan="2">Пол. контакта заземл.</td><td colspan="2">6 ч</td></tr> <tr><td colspan="2">Номинальный ток (А)</td><td>16</td><td>32</td></tr> <tr><td colspan="2">Полюсы</td><td colspan="2">5</td></tr> <tr><td colspan="2">Размеры (мм)</td><td>a</td><td>75</td><td>75</td></tr> <tr><td colspan="2"></td><td>b</td><td>75</td><td>75</td></tr> <tr><td colspan="2"></td><td>c</td><td>47.7</td><td>63.5</td></tr> <tr><td colspan="2"></td><td>d</td><td>60</td><td>60</td></tr> <tr><td colspan="2"></td><td>e</td><td>60</td><td>60</td></tr> <tr><td colspan="2"></td><td>f</td><td>5.5</td><td>5.5</td></tr> <tr><td colspan="2"></td><td>g</td><td>6</td><td>6</td></tr> <tr><td colspan="2"></td><td>h</td><td>90.3</td><td>108.5</td></tr> <tr><td colspan="2"></td><td>k</td><td>23</td><td>25</td></tr> <tr><td colspan="2"></td><td>l</td><td>55</td><td>61.5</td></tr> <tr><td colspan="2">Номинальное сечение кабеля (мм²)</td><td>1-2.5</td><td>2.5-6</td></tr> </table>	Пол. контакта заземл.		6 ч		Номинальный ток (А)		16	32	Полюсы		5		Размеры (мм)		a	75	75			b	75	75			c	47.7	63.5			d	60	60			e	60	60			f	5.5	5.5			g	6	6			h	90.3	108.5			k	23	25			l	55	61.5	Номинальное сечение кабеля (мм²)		1-2.5	2.5-6
Пол. контакта заземл.		6 ч																																																																			
Номинальный ток (А)		16	32																																																																		
Полюсы		5																																																																			
Размеры (мм)		a	75	75																																																																	
		b	75	75																																																																	
		c	47.7	63.5																																																																	
		d	60	60																																																																	
		e	60	60																																																																	
		f	5.5	5.5																																																																	
		g	6	6																																																																	
		h	90.3	108.5																																																																	
		k	23	25																																																																	
		l	55	61.5																																																																	
Номинальное сечение кабеля (мм²)		1-2.5	2.5-6																																																																		
	<p>УНТ-N3332 УНТ-N3432 Ток (А): 63А, 125А Напряжение (В): 220-250В~ 2P+E Класс защиты: IP67</p>		<table border="1"> <tr><td colspan="2">Пол. контакта заземл.</td><td colspan="2">6 ч</td></tr> <tr><td colspan="2">Номинальный ток (А)</td><td>16</td><td>32</td></tr> <tr><td colspan="2">Полюсы</td><td colspan="2">3</td></tr> <tr><td colspan="2">Размеры (мм)</td><td>a</td><td>55</td><td>75</td></tr> <tr><td colspan="2"></td><td>b</td><td>51</td><td>61</td></tr> <tr><td colspan="2"></td><td>c</td><td>45</td><td>60</td></tr> <tr><td colspan="2"></td><td>d</td><td>45</td><td>60</td></tr> <tr><td colspan="2"></td><td>e</td><td>75</td><td>96</td></tr> <tr><td colspan="2"></td><td>f</td><td>19</td><td>20</td></tr> <tr><td colspan="2"></td><td>g</td><td>33</td><td>41</td></tr> <tr><td colspan="2"></td><td>h</td><td>44</td><td>58</td></tr> <tr><td colspan="2">Номинальное сечение кабеля (мм²)</td><td>1-2.5</td><td>2.5-6</td></tr> </table>	Пол. контакта заземл.		6 ч		Номинальный ток (А)		16	32	Полюсы		3		Размеры (мм)		a	55	75			b	51	61			c	45	60			d	45	60			e	75	96			f	19	20			g	33	41			h	44	58	Номинальное сечение кабеля (мм²)		1-2.5	2.5-6										
Пол. контакта заземл.		6 ч																																																																			
Номинальный ток (А)		16	32																																																																		
Полюсы		3																																																																			
Размеры (мм)		a	55	75																																																																	
		b	51	61																																																																	
		c	45	60																																																																	
		d	45	60																																																																	
		e	75	96																																																																	
		f	19	20																																																																	
		g	33	41																																																																	
		h	44	58																																																																	
Номинальное сечение кабеля (мм²)		1-2.5	2.5-6																																																																		

Соединительные клеммы

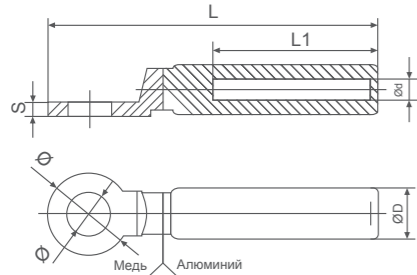

Медно-алюминиевые соединительные клеммы DTL-2

Модель	Размеры (мм)						
	ØD	Ød	S	L	L1	Ø	Ø1
DTL-2-10	12	5.2	3.5	80	40	10.5	20
DTL-2-16	12	6.1	3.5	80	40	10.5	20
DTL-2-25	16	7.1	4.0	90	45	13	24
DTL-2-35	16	8.5	4.0	90	45	13	24
DTL-2-50	20	9.8	5.0	95	47	13	24
DTL-2-70	20	11.5	5.0	95	47	13	24
DTL-2-95	20	13.5	5.0	95	47	13	24
DTL-2-120	25	15	5.5	119	60	13	30
DTL-2-150	25	17	5.5	119	60	13	30
DTL-2-185	32	18.5	6.2	128	62	13	35
DTL-2-240	32	21.5	6.2	128	62	13	35
DTL-2-300	34	24	7.0	140	72	13	36
DTL-2-400	42	27	7.5	165	85	17	40
DTL-2-500	42	30	7.5	165	85	17	40

Примечание: Расшифровка DTL-2-10.
D: клеммы; T: медь; L: алюминий; 2: круглая головка; 10: сечение проводника.

Общая информация

Соединительные клеммы используются для соединения проводов и кабелей в распределительном и электрическом оборудовании. Алюминиевые соединительные клеммы серии DL спрессованы с алюминиевым стержнем (L3), медные соединительные клеммы серии DT спрессованы с медным стержнем (T2).

Медные соединительные клеммы DT

Модель	Размеры (мм)						
	Ø	D	d	L	L1	W	S
DT-10	8.5	9	5.2	62	26	16	2.5
DT-16	8.5	10	6.1	68	30	16	2.5
DT-25	8.5	11	7.1	70	33	18	2.7
DT-35	10.5	12	8.5	80	36	20.5	3.0
DT-50	10.5	14	9.8	86	38	23	3.4
DT-70	12.5	16	11.5	95	43	26	3.8
DT-95	12.5	18	13.5	104	46	28	4.2
DT-120	14.5	20	15	112	49	30	4.7
DT-150	14.5	22	17	120	51	34	5.5
DT-185	16.5	25	18.6	126	55	37	5.8
DT-240	16.5	27	21.5	137	60	40	6.5
DT-300	21	31	24	158	68	50	8.0
DT-400	21	34	27	175	78	50	9.0
DT-500	21	38	30	186	82	60	10.0
DT-630	21	45	34.2	215	86	80	12.0

Примечание: Расшифровка DT-10.
D: клеммы; T: медь; 10: сечение проводника.

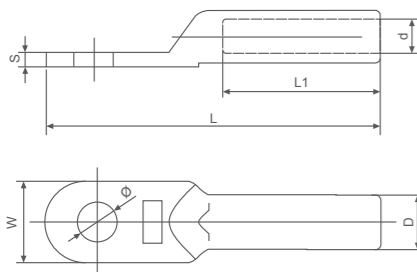

Соединительные клеммы

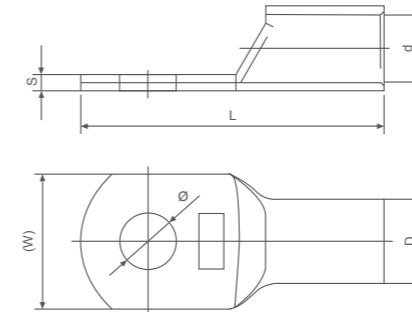

Общая информация

Клеммы предназначены для соединения медных силовых проводников (площадь сечения 1,5-1000 мм²) электронного оборудования, изготовлены из медной трубки T2 и покрыты оловом. Рабочая температура -55...+150°C.

Медные клеммы SC(JGK)

Модель	Размеры (мм)					
	Ø	D	d	L	(W)	S
SC(JGK)-1.5	4.2, 5.2	3.5	2.5	18	7	1
SC(JGK)-2.5	4.2, 5.2	4	3	19	8	1
SC(JGK)-4	5.2, 6.4	4.8	3.5	20	8	1.2
SC(JGK)-6	5.2, 6.4	5.5	4.1	23	9	1.4
SC(JGK)-10	6.4, 8.4	6.7	5	25.5	11	1.6
SC(JGK)-16	6.4, 8.4	7.5	5.8	30	12	1.8
SC(JGK)-25	6.4, 8.4, 10.5	9	7.2	32.5	13	1.8
SC(JGK)-35	6.4, 8.4, 10.5	10.5	8.5	37	15	2
SC(JGK)-50	8.4, 10.5	12.5	10.1	45	18	2.4
SC(JGK)-70	10.5, 12.5	14.5	11.7	49	21	2.8
SC(JGK)-95	10.5, 12.5	17	13.8	54	25	3.2
SC(JGK)-120	12.5, 16.5	19.5	15.9	62	28	3.6
SC(JGK)-150	12.5, 16.5	20.5	16.7	68	30	3.8
SC(JGK)-185	16.5	23.5	19.1	76	34	4.4
SC(JGK)-240	16.5	26	21.4	90	38	4.6
SC(JGK)-300	16.5, 20.5	30	24.6	100	44	5.4
SC(JGK)-400	16.5, 20.5	34	27.4	110	50	6.6
SC(JGK)-500	16.5, 20.5	38	30.8	120	55	7.2
SC(JGK)-630	20.5	45	35.6	135	65	9.2
SC(JGK)-800	22.5	50	40.4	170	72	9.6
SC(JGK)-1000	22.5	55	45	200	80	10

Общая информация

Клеммы предназначены для соединения круглых и полукруглых проводников в распределительном оборудовании или силовых кабелях. Трубки серии GTL изготавливаются методом высококачественной сварки трением.

Медно-алюминиевая соединительная трубка GTL (с)

Модель	Размеры (мм)						
	D	d	D1	d1	L1	L2	L
GTL-16	11	6.1	9	5.2	30	25	70
GTL-25	12	7.1	10	6.1	33	27	75
GTL-35	14	8.5	11	7.1	40	30	85
GTL-50	16	9.8	13	8.5	42	32	95
GTL-70	18	11.5	15	9.8	46	38	105
GTL-95	21	13.5	17	11.5	50	40	110
GTL-120	23	15	19	13.5	55	42	112
GTL-150	25	17	21	15	55	44	118
GTL-185	27	18.6	23	17	58	46	125
GTL-240	30	21.5	26	18.6	60	54	130
GTL-300	34	24	28	21.5	66	56	145
GTL-400	38	27	30	24	70	60	155
GTL-500	45	30	34	27	75	65	165

Примечание: расшифровка GTL-16
G: клеммы; T: медь; L: алюминий; 16: сечение проводника.

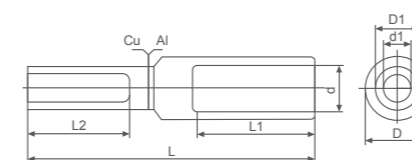

Соединительные клеммы

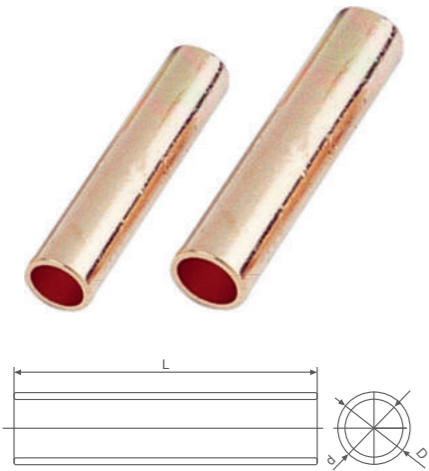

Общая информация

Клеммы предназначены для соединения круглых и полукруглых проводов в распределительном оборудовании или силовых кабелях. Соединительная клемма GT изготовлена из медной трубки методом высококачественной сварки трением.

Медная соединительная трубка GT (проходная)

Модель	Размеры (мм)		
	D	d	L
GT-1-10	8	5	52
GT-1-16	9	6	56
GT-1-25	10	7	60
GT-1-35	11	8.4	65
GT-1-50	13	10	73
GT-1-70	16	12	80
GT-1-95	18	14	85
GT-1-120	19	15	93
GT-1-150	22	17	100
GT-1-185	24	19	105
GT-1-240	26	21	110
GT-1-300	31	24	120
GT-1-400	34	26	135
GT-1-500	38	30	150
GT-1-630	45	35	170
GT-1-800	50	40	225
GT-1-1000	55	45	250

Примечание: расшифровка GT-2-1.5
G: соединительная трубка; T: медь; 1: защита от масла; 1.5: сечение проводника.

Медная соединительная трубка GTY (проходная)

Модель	Размеры (мм)		
	D	d	L
GTY-1.5	3.7	2.5	20
GTY-2.5	4	3	20
GTY-4	4.8	3.3	20
GTY-5.5	5.5	4.3	25
GTY-10	6.8	4.8	30
GTY-16	7.5	5.5	35
GTY-25	9	7	40
GTY-35	10.5	8.2	45
GTY-50	12.5	9.8	50
GTY-70	14.5	11.5	55
GTY-95	17.5	13.5	60
GTY-120	19.5	15	65
GTY-150	21	16.5	70
GTY-185	23.5	18.5	75
GTY-240	26.5	21	80
GTY-300	30	24	85
GTY-400	34	27	90
GTY-500	38	30	100
GTY-630	45	35	110
GTY-800	50	39	150
GTY-1000	56	44	170

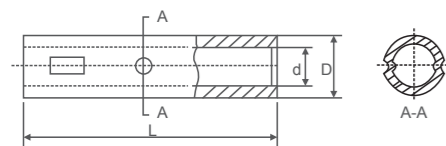

Кольцевые клеммы с изоляцией



Сечение проводника: 0.5-1.5 мм²; Американский калибр: 22-16;
Максимальный ток: I_{max}=19 A

Модель	Типоразмер болта	Размеры						Цвет
		Диаметр отверстия d2	B мм	L мм	F мм	H мм	DØ мм	
RV1.25-3	#4	3.2 мм	5.7	17.8	4.95	10.0	4.3	Красный
RVS1.25-3.5	#6	3.7 мм	5.7	17.8	4.95			
RVM1.25-3.5	#6	3.7 мм	6.6	20.1	6.3			
RV1.25-5S	#10	5.3 мм	8.0	21.5	7.0			
RV1.25-5L	#10	5.3 мм	9.5	23.3	8.0			
RVS1.25-4	#8	4.3 мм	6.8	20.1	6.3			
RVL1.25-4	#8	4.3 мм	8.0	21.5	7.0			
RV1.25-5	#10	5.3 мм	8.0	21.5	7.0			
RV1.25-6	1/4	6.5 мм	11.6	27.5	11.1			
RV1.25-8	5/16	8.4 мм	11.6	27.5	11.1			
RV1.25-12	3/8	10.5 мм	13.6	31.6	13.9			

Сечение проводника: 1.5-2.5 мм²; Американский калибр: 16-14;
Максимальный ток: I_{max}=27 A

Модель	Типоразмер болта	Размеры						Цвет
		Диаметр отверстия d2	B мм	L мм	F мм	H мм	DØ мм	
RV2-3	#4	3.2 мм	6.6	17.8	4.3	10.0	4.9	Синий
RVS2-3.5	#6	3.7 мм	6.6	17.8	4.3			
RVS2-4	#8	4.3 мм	6.6	21.0	7.0			
RVL2-4	#8	4.3 мм	8.5	22.5	7.75			
RVS2-5	#10	5.3 мм	8.5	22.5	7.75			
RVL2-5	#10	5.3 мм	9.5	22.5	7.25			
RV2-6	1/4	6.5 мм	12.0	27.6	11.0			
RV2-8	5/16	8.4 мм	12.0	27.6	11.0			
RV2-10	3/8	10.5 мм	13.6	30.2	13.9			

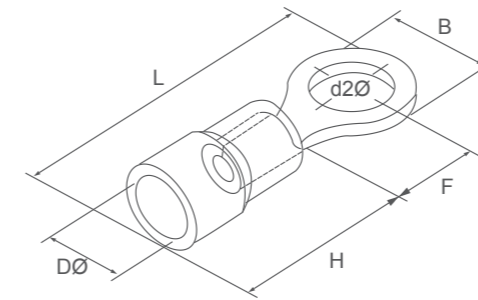

Сечение проводника: 2.5-4 мм²; Американский калибр: 14-12;
Максимальный ток: I_{max}=37 A

Модель	Типоразмер болта	Размеры						Цвет
		Диаметр отверстия d2	B мм	L мм	F мм	H мм	DØ мм	
RV3.5-4	#8	4.3 мм	8.0	24.5	7.7	12.5	6.2	Черный
RV3.5-5	#10	5.3 мм	8.0	24.5	7.7			
RV3.5-6	1/4	6.5 мм	12.0	27.9	7.7			
RV3.5-8	5/16	8.4 мм	15.0	32.0	13.5			
RV3.5-10	3/8	10.5 мм	15.0	32.0	13.5			

Сечение проводника: 4-6 мм²; Американский калибр: 12-10;
Максимальный ток: I_{max}=48 A

Модель	Типоразмер болта	Размеры						Цвет
		Диаметр отверстия d2	B мм	L мм	F мм	H мм	DØ мм	
RV5.5-3.5	#6	3.7 мм	7.2	21.4	5.9	12.5	6.7	Желтый
RVS5.5-4	#8	4.3 мм	7.2	21.4	5.9			
RVL5.5-4	#8	4.3 мм	9.5	25.5	8.3			
RV5.5-5	#10	5.3 мм	9.5	25.5	8.3			
RV5.5-6	1/4	6.5 мм	12.0	31.5	13.0			
RV5.5-8	5/16	8.4 мм	15.0	33.7	13.7			
RV5.5-10	3/8	10.5 мм	15.0	33.7	13.7			
RV5.5-12	1/2	13.0 мм	19.2	38.1	16.0			

Электрические аксессуары

Кольцевые клеммы без изоляции

Сечение проводника: 0.5-1.5 мм²; Американский калибр: 22-16;
Максимальный ток: I_{max}=19 A



Модель	Типоразмер болта	Размеры						
		Диаметр отверстия	B	L	F	H	DØ	dØ
		d2	мм	мм	мм	мм	мм	мм
RNB1.25-3	#4	3.2 мм	5.7	12.6	4.95	10.0	4.3	1.7
RNBS1.25-3.5	#6	3.7 мм	5.7	12.6	4.95			
RNBM1.25-3.5	#6	3.7 мм	6.6	14.4	6.3			
RNBS1.25-4	#8	4.3 мм	6.8	14.4	6.3			
RNBL1.25-4	#8	4.3 мм	8.0	15.8	7.0			
RNB1.25-5	#10	5.3 мм	8.0	15.8	7.0			
RNB1.25-6	1/4	5.3 мм	11.6	21.8	11.1			
RNB1.25-8	5/16	8.4 мм	11.6	21.8	11.1			
RNB1.25-10	3/8	10.5 мм	13.6	25.5	13.9			

Сечение проводника: 1.5-2.5 мм²; Американский калибр: 16-14;
Максимальный ток: I_{max}=27 A

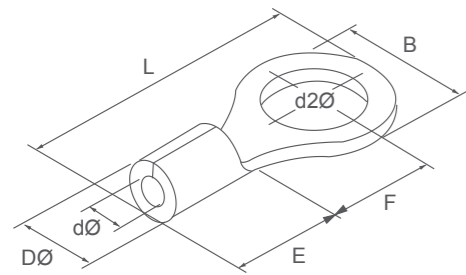

Модель	Типоразмер болта	Размеры						
		Диаметр отверстия	B	L	F	H	DØ	dØ
		d2	мм	мм	мм	мм	мм	мм
RNB2-3	#4	3.2 мм	6.6	12.3	4.3	4.8	4.1	2.3
RNBS2-4	#8	4.3 мм	6.6	16.0	7.0			
RNBL2-4	#8	4.3 мм	8.5	16.8	7.75			
RNBS2-5	#10	5.3 мм	8.5	16.8	7.75			
RNBL2-5	#10	5.3 мм	9.5	16.8	7.25			
RNB2-6	1/4	6.5 мм	12.0	21.8	11.0			
RNB2-8	5/16	8.4 мм	12.0	21.8	11.0			
RNB2-12	3/8	10.5 мм	13.6	25.5	13.9			

Сечение проводника: 2.5-4 мм²; Американский калибр: 14-12;
Максимальный ток: I_{max}=37 A

Модель	Типоразмер болта	Размеры						
		Диаметр отверстия	B	L	F	H	DØ	dØ
		d2	мм	мм	мм	мм	мм	мм
RNB3.5-4	#8	4.3 мм	8.0	18.0	7.7	6.5	5.0	3.0
RNBS3.5-5	#10	5.3 мм	8.0	18.0	7.7			
RNBL3.5-5	#10	5.3 мм	12.0	12.0	7.7			
RNB3.5-6	1/4	6.5 мм	12.0	12.0	7.7			
RNB3.5-8	5/16	8.4 мм	15.0	27.0	13.5			
RNB3.5-10	3/8	10.5 мм	15.0	27.0	13.5			

Сечение проводника: 4-6 мм²; Американский калибр: 12-10;
Максимальный ток: I_{max}=48 A

Модель	Типоразмер болта	Размеры						
		Диаметр отверстия	B	L	F	H	DØ	dØ
		d2	мм	мм	мм	мм	мм	мм
RNBS5.5-4	#8	4.3 мм	7.2	15.7	5.9	6.8	5.6	3.4
RNBL5.5-4	#8	4.3 мм	9.5	19.8	8.3			
RNB5.5-6	1/4	6.5 мм	12.0	25.8	13.0			
RNB5.5-8	5/16	8.4 мм	15.0	28.0	13.7			
RNB5.5-10	3/8	10.5 мм	15.0	28.0	13.7			
RNB5.5-12	1/2	13.0 мм	19.2	32.4	16			

Электрические аксессуары

Кольцевые клеммы без изоляции

Сечение проводника: 6-10 мм²; Американский калибр: 8;
Максимальный ток: I_{max}=62 A



Модель	Типоразмер болта	Размеры						
		Диаметр отверстия	B	L	F	H	DØ	dØ
		d2	мм	мм	мм	мм	мм	мм
RNB8-4	#8	4.3 мм	12.0	23.8	9.3	8.5	7.2	4.5
RNBS8-5	#10	5.3 мм	8.8	23.8	11.1			
RNBM8-5	#10	5.3 мм	12.0	23.8	9.3			
RNBL8-5	#10	5.3 мм	15.0	29.8	13.8			
RNBS8-6	1/4	6.5 мм	12.0	23.8	9.3			
RNBL8-6	1/4	6.5 мм	15.0	29.8	13.8			
RNB8-8	5/16	8.4 мм	15.0	29.8	13.8			
RNB8-10	3/8	10.5 мм	15.0	29.8	13.8			

Сечение проводника: 10-16 мм²; Американский калибр: 6;
Максимальный ток: I_{max}=88 A

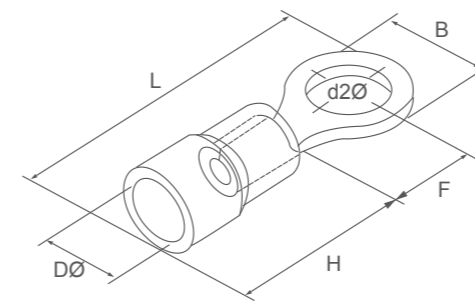

Модель	Типоразмер болта	Размеры						
		Диаметр отверстия	B	L	F	H	DØ	dØ
		d2	мм	мм	мм	мм	мм	мм
RNB14-4	#8	4.3 мм	12.0	29.8	13.3	10.5	9.0	5.8
RNB14-5	#10	5.3 мм	12.0	29.8	13.3			
RNBS14-6	1/4	6.5 мм	12.0	29.8	13.3			
RNBL14-6	1/4	6.5 мм	16.0	32.8	13.3			
RNB14-8	5/16	8.4 мм	16.0	32.8	14.5			
RNB14-10	3/8	10.5 мм	16.0	32.8	14.5			
RNB14-12	1/2	13.0 мм	22.0	41.0	19.5			

Сечение проводника: 16-25 мм²; Американский калибр: 4;
Максимальный ток: I_{max}=115 A

Модель	Типоразмер болта	Размеры						
		Диаметр отверстия	B	L	F	H	DØ	dØ
		d2	мм	мм	мм	мм	мм	мм
RNBS22-5	#10	5.3 мм	12.2	33.2	14.5	12.0	11.5	7.7
RNBL22-5	#10	5.3 мм	16.5	33.7	13.5			
RNBS22-6	1/4	6.3 мм	12.2	33.2	14.5			
RNBL22-6	1/4	6.3 мм	16.5	33.7	13.5			
RNB22-8	5/16	8.4 мм	16.5	33.7	13.5			
RNB22-10	3/8	10.5 мм	16.5	33.7	13.5			
RNB22-11	7/16	11.5 мм	22.0	42.5	19.5			
RNB22-12	1/2	13.0 мм	22.0	42.5	19.5			

Сечение проводника: 25-50 мм²; Американский калибр: 4;
Максимальный ток: I_{max}=160 A

Модель	Типоразмер болта	Размеры						
		Диаметр отверстия	B	L	F	H	DØ	dØ
		d2	мм	мм	мм	мм	мм	мм
RNB38-5	#10	5.3 мм	15.3	39.0	18.3	14.0	13.5	9.4
RNB38-6	1/4	6.5 мм	15.3	39.0	18.3			
RNBS38-8	5/16	8.4 мм	15.3	39.0	18.3			
RNBL38-8	5/16	8.4 мм	22.0	42.7	17.7			
RNBS38-10	3/8	10.5 мм	15.3	39.0	8.3			
RNBL38-10	3/8	10.5 мм	22.0	42.7	17.7			
RNB38-11	7/16	11.5 мм	22.0	42.7	17.7			
RNB38-12	1/2	13.0 мм	22.0	42.7	17.7			

Электрические аксессуары

Вилочный наконечник с изоляцией

Сечение проводника: 1.5-2.5 мм²; Американский калибр: 16-14;
Максимальный ток: I_{max}=27 А



Модель	Типоразмер болта	Размеры						Цвет
		Диаметр отверстия	B	L	F	H	DØ	
		d2	мм	мм	мм	мм	мм	
SV1.25-3	#4	3.2 мм	5.7	21.2	6.5	10.0	4.3	Красный
SV1.25-3.5	#6	3.7 мм	5.7	21.2	6.5			
SVM1.25-4	#8	4.3 мм	7.2	21.2	6.5			
SVL1.25-4	#8	4.3 мм	8.1	21.2	6.5			
SVS1.25-5	#10	5.3 мм	8.1	21.2	6.5			
SVL1.25-5	#10	5.3 мм	9.5	21.2	6.5			
SVS1.25-6	1/4	6.5 мм	9.5	21.2	6.5			
SVL1.25-6	1/4	6.5 мм	12.0	27.2	11.0			

Сечение проводника: 1.5-2.5 мм²; Американский калибр: 16-14;
Максимальный ток: I_{max}=27 А

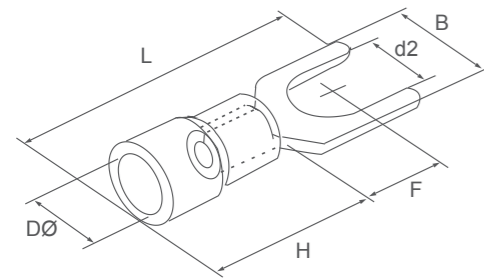

Модель	Типоразмер болта	Размеры						Цвет
		Диаметр отверстия	B	L	F	H	DØ	
		d2	мм	мм	мм	мм	мм	
SV2-3	#4	3.2 мм	5.7	21.2	6.5	10.0	4.9	Синий
SVS2-3.5	#6	3.7 мм	5.7	21.2	6.5			
SVS2-4	#8	4.3 мм	6.4	21.2	6.5			
SVM2-4	#8	4.3 мм	7.2	21.2	6.5			
SVL2-4	#8	4.3 мм	8.1	21.2	6.5			
SVS2-5	#10	5.3 мм	8.1	21.2	6.5			
SVL2-5	#10	5.3 мм	9.5	21.2	6.5			
SVS2-6	1/4	6.5 мм	9.5	21.2	6.5			
SVL2-6	1/4	6.5 мм	12.0	27.2	11.0			

Сечение проводника: 2.5-4мм²; Американский калибр: 14-12;
Максимальный ток: I_{max}=37А

Модель	Типоразмер болта	Размеры						Цвет
		Диаметр отверстия	B	L	F	H	DØ	
		d2	мм	мм	мм	мм	мм	
SV3.5-4	#8	4.3 мм	8.0	24.8	7.0	12.5	6.2	Черный
SV3.5-5	#10	5.3 мм	8.0	24.8	7.0			
SV3.5-6	1/4	6.5 мм	12.0	28.0	12.1			

Сечение проводника: 4-6мм²; Американский калибр: 12-10;
Максимальный ток: I_{max}=48А

Модель	Типоразмер болта	Размеры						Цвет
		Диаметр отверстия	B	L	F	H	DØ	
		d2	мм	мм	мм	мм	мм	
SV5.5-3	#6	3.7 мм	8.3	25.2	7.5	12.5	6.7	Желтый
SVS5.5-4	#8	4.3 мм	8.3	25.2	7.5			
SVL5.5-4	#8	4.3 мм	9.0	25.2	7.5			
SV5.5-5	#10	5.3 мм	9.0	25.2	7.5			
SVS5.5-6	1/4	6.5 мм	9.0	25.2	7.5			
SVL5.5-6	1/4	6.5 мм	12.0	31.2	12.0			
SV5.5-8	5/16	8.4 мм	14.0	30.0	11.5			

Электрические аксессуары

Вилочный наконечник без изоляции

Сечение проводника: 0.5-1.5мм²; Американский калибр: 22-16;
Максимальный ток: I_{max}=19А



Модель	Типоразмер болта	Размеры						DØ	dØ
		Диаметр отверстия	B	L	F	H			
		d2	мм	мм	мм	мм			
SNB1.25-3	#4	3.2 мм	5.7	16.0	6.5	4.8	3.4	1.7	
SNBS1.25-3.5	#6	3.7 мм	5.7	16.0	6.5				
SNBS1.25-4	#8	4.3 мм	6.4	16.0	6.5				
SNBM1.25-4	#8	4.3 мм	7.2	16.0	6.5				
SNBS1.25-5	#10	5.3 мм	8.1	16.0	6.5				
SNBS1.25-6	1/4	6.5 мм	9.5	16.0	6.5				

Сечение проводника: 1.5-2.5мм²; Американский калибр: 16-14;
Максимальный ток: I_{max}=27А

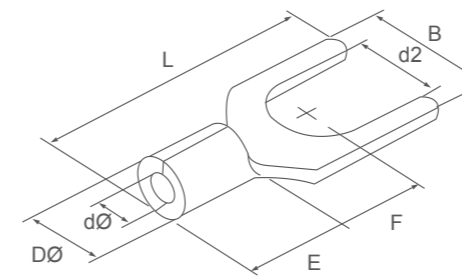

Модель	Типоразмер болта	Размеры						DØ	dØ
		Диаметр отверстия	B	L	F	H			
		d2	мм	мм	мм	мм			
SNB2-3	#4	3.2 мм	5.7	16.0	6.5	4.8	4.1	2.3	
SNBS2-3.5	#6	3.7 мм	5.7	16.0	6.5				
SNB2-4	#8	4.3 мм	6.4	16.0	6.5				
SNBM2-4	#8	4.3 мм	7.2	16.0	6.5				
SNLS2-5	#10	5.3 мм	9.5	16.0	6.5				
SNBS2-6	1/4	6.5 мм	9.5	16.0	6.5				
SNBL2-8	1/4	6.5 мм	12.0	22.0	11.0				

Сечение проводника: 2.5-4мм²; Американский калибр: 14-12;
Максимальный ток: I_{max}=37А

Модель	Типоразмер болта	Размеры						DØ	dØ
		Диаметр отверстия	B	L	F	H			
		d2	мм	мм	мм	мм			
SNB3.5-4	#8	4.3 мм	8.0	18.3	7.0	6.0	5.0	3.0	
SNB3.5-5	#10	5.3 мм	8.0	18.3	7.0				
SNB3.5-6	1/4	6.5 мм	12.0	21.5	12.1				

Сечение проводника: 4-6мм²; Американский калибр: 12-10;
Максимальный ток: I_{max}=48А

Модель	Типоразмер болта	Размеры						DØ	dØ
		Диаметр отверстия	B	L	F	H			
		d2	мм	мм	мм	мм			
SNBS5.5-4	#8	4.3 мм	8.3	19.5	7.5	6.8	5.6	3.4	
SNBS5.5-5	#10	5.3 мм	9.0	19.5	7.7				
SNBS5.5-6	1/4	6.5 мм	9.0	19.5	7.5				

Электрические аксессуары

Внутренние/внешние коннекторы с изоляцией



Внутренние коннекторы с изоляцией

Сечение проводника: 0.5-1.5 мм²; Американский калибр: 22-18;
Максимальный ток: I_{max}=19 A; Материал: латунь

Модель	Обозн. NEMA	Толщина материала	Размеры (мм)					Цвет
			B	d∅	D∅	L	H	
FDD1.25-110(5)	0.5x2.8	0.3	3.8	1.7	3.8	19.0	10.0	Красный
FDD1.25-110(8)	0.8x2.8	0.3	3.8	1.7	3.8	19.0		
FDD1.25-187(5)	0.5x4.75	0.35	5.6	1.7	3.8	19.0		
FDD1.25-187(8)	0.8x4.75	0.35	5.6	1.7	3.8	19.0		
FDD1.25-250	0.8x6.35	0.4	7.4	1.7	3.8	21.0		

Сечение проводника: 1.5-2.5 мм²; Американский калибр: 16-14;
Максимальный ток: I_{max}=15 A; Материал: латунь

Модель	Обозн. NEMA	Толщина материала	Размеры (мм)					Цвет
			B	d∅	D∅	L	H	
FDD2-110(5)	0.5x2.8	0.3	3.8	2.3	4.3	19.0	10.0	Синий
FDD2-110(8)	0.8x2.8	0.3	3.8	2.3	4.3	19.0		
FDD2-187(5)	0.5x4.75	0.35	5.6	2.3	4.3	19.0		
FDD2-187(8)	0.8x4.75	0.35	5.6	2.3	4.3	19.0		
FDD2-250	0.8x6.35	0.4	7.4	2.3	4.3	21.0		

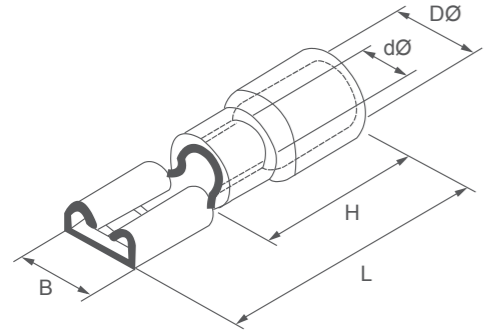

Сечение проводника: 4-6 мм²; Американский калибр: 12-10;
Максимальный ток: I_{max}=24 A; Материал: латунь

Модель	Обозн. NEMA	Толщина материала	Размеры (мм)					Цвет
			B	d∅	D∅	L	H	
FDD5-250	0.8x6.35	0.4	7.4	3.3	5.7	25.0	13.0	Желтый

Внешние коннекторы с изоляцией

Сечение проводника: 0.5-1.5 мм²; Американский калибр: 22-18;
Максимальный ток: I_{max}=10 A; Материал: латунь

Модель	Обозн. NEMA	Толщина материала	Размеры (мм)					Цвет
			B	d∅	D∅	L	H	
MDD1.25-187	0.5x4.75	0.5	4.75	1.70	4.3	20.0	10.0	Красный



Сечение проводника: 0.5-1.5 мм²; Американский калибр: 22-18;
Максимальный ток: I_{max}=15 A; Материал: латунь

Модель	Обозн. NEMA	Толщина материала	Размеры (мм)					Цвет
			B	d∅	D∅	L	H	
MDD2-187	0.5x4.75	0.5	4.75	2.3	4.3	20.0	10.0	Синий
MDD2-250	0.8x6.35	0.4*2	6.35	2.3	4.3	21.0		

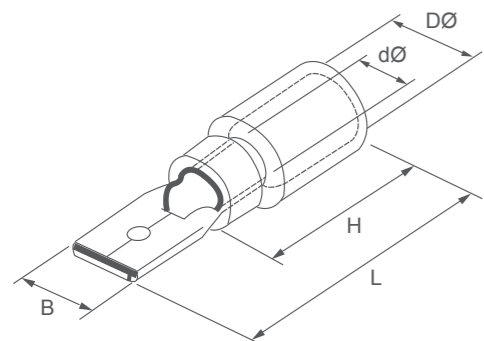

Сечение проводника: 4-6 мм²; Американский калибр: 12-10;
Максимальный ток: I_{max}=24 A; Материал: латунь

Модель	Обозн. NEMA	Толщина материала	Размеры (мм)					Цвет
			B	d∅	D∅	L	H	
MDD5.5-250	0.8x6.35	0.4*2	6.35	3.4	5.7	25.0	13.0	Желтый

Электрические аксессуары

Разъединители с изоляцией



Внутренний разъединитель с изоляцией

Сечение проводника: 0.5-1.5 мм²; Американский калибр: 22-16;
Максимальный ток: I_{max}=10 A; Материал: латунь

Модель	Толщина материала	Размеры (мм)					Цвет
		b∅	B∅	D∅	F	L	
FRD1.25-156	0.4	4.0	6.3	1.7	13.0	24.5	Красный

Сечение проводника: 1.5-2.5 мм²; Американский калибр: 16-14;
Максимальный ток: I_{max}=15 A; Материал: латунь

Модель	Толщина материала	Размеры (мм)					Цвет
		b∅	B∅	D∅	F	L	
FRD2-156	0.4	4.0	6.3	2.3	14.0	24.5	Синий
FRD2-195	0.4	5.0	7.0	2.3	14.0	24.5	

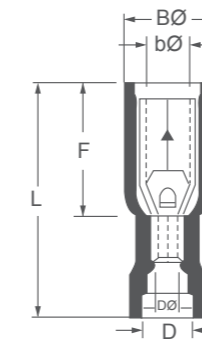

Сечение проводника: 4-6 мм²; Американский калибр: 12-10;
Максимальный ток: I_{max}=24 A; Материал: латунь

Модель	Толщина материала	Размеры (мм)					Цвет
		b∅	B∅	D∅	F	L	
FRD5.5-195	0.4	5.0	7.3	3.4	14.0	29.5	Желтый

Внешние разъединители с изоляцией

Сечение проводника: 0.5-1.5 мм²; Американский калибр: 22-16;
Максимальный ток: I_{max}=10 A; Материал: латунь

Модель	Толщина материала	Размеры (мм)					Цвет
		b∅	F	D∅	H	L	
MPD1.25-156	0.4	4.0	6.3	1.7	13.0	24.5	Красный

Сечение проводника: 1.5-2.5 мм²; Американский калибр: 16-14;
Максимальный ток: I_{max}=15 A; Материал: латунь

Модель	Толщина материала	Размеры (мм)					Цвет
		b∅	F	D∅	H	L	
MPD2-156	0.4	4.0	11.0	2.3	10.0	21.0	Синий
MPD2-195	0.4	5.0	11.0	2.3	10.0	21.0	

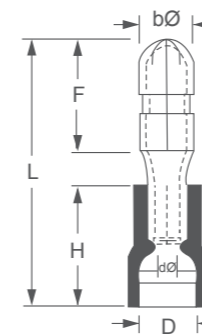

Сечение проводника: 4-6 мм²; Американский калибр: 12-10;
Максимальный ток: I_{max}=24 A; Материал: латунь

Модель	Толщина материала	Размеры (мм)					Цвет
		b∅	F	D∅	H	L	
MPD5.5-195	0.4	5.0	12.0	3.4	13.0	25.0	Желтый

Электрические аксессуары

Соединители и разъединители с изоляцией



Соединители с изоляцией

Материал: медь; изоляция: ПВХ

Модель	Сечение проводника		Размеры (мм)			Макс. ток	Цвет
	Амер. кал.	мм ²	B	dØ	L		
BV1.5	22-16	0.5-1.5	15.0	1.7	26.0	19 A	Красный
BV2	16-14	0.5-1.5	15.0	2.3	26.0	27 A	Синий
BV5.5	12-10	4-6	15.0	3.4	26.0	48 A	Желтый
BV8	#8	6-10	21.0	4.5	32.0	62 A	Красный
BV14	#6	10-16	26.0	5.8	42.0	88 A	Синий
BV22	#4	16-25	29.0	7.7	50.0	115 A	Желтый

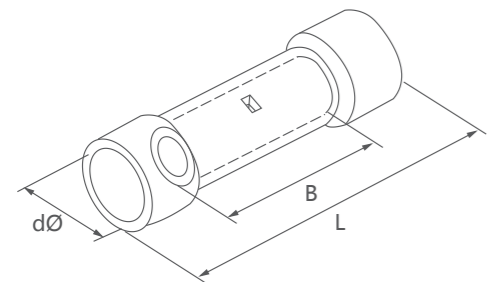

Стыковые соединители с изоляцией

Материал: медь; материал изоляции: ПВХ

Модель	Сечение проводника		Размеры (мм)			Макс. ток	Цвет
	Амер. кал.	мм ²	B	dØ	L		
PVT1.25	22-16	0.5-1.5	8.0	1.7	16.0	19 A	Красный
PVT2	16-14	1.5-2.5	8.0	2.3	16.0	27 A	Синий
PVT5.5	12-10	4-6	8.5	3.4	20.5	48 A	Желтый

Стыковые разъединители с изоляцией

Американский калибр 26-22, максимальный ток: 9 А. Американский калибр 16-14, максимальный ток: 27 А. Американский калибр 12-10, максимальный ток: 48 А. Предельная рабочая температура: 105°C, 600 В; изоляция: нейлон

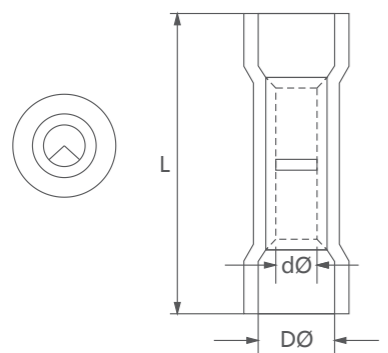

Модель	Размеры (мм)			Материал соединит.	Сечение проводника	Цвет
	L	DØ	dØ			
BNYF0.5	20.0	2.0	1.3	Медная трубка	26-22 A.W.G 0.2-0.5 мм ²	Желтый
BNYF1.25	27.3	3.2	1.7	Медная трубка	22-16 A.W.G 0.5-1.5 мм ²	Красный
BNYF2	27.3	3.8	2.3	Медная трубка	16-14 A.W.G 1.5-2.5 мм ²	Синий
BNYF5.5	27.3	5.3	3.4	Медная трубка	14-10 A.W.G 15-6 мм ²	Желтый

Электрические аксессуары

Разъединители с виниловой изоляцией и разъединители с фиксатором и изоляцией

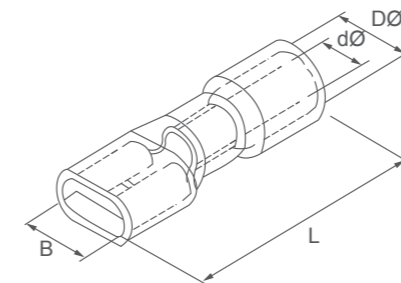

Разъединители с виниловой изоляцией

Сечение проводника: 0.5-1.5 мм²; Американский калибр: 22-16; Максимальный ток: I_{max}=15 А; Материал: латунь

Модель	Обозн. NEMA	Размеры (мм)			
		B	DØ	dØ	L
FDFD1.25-187(5)	0.5x4.75	5.6	3.8	1.7	20.0
FDFD1.25-187(8)	0.8x4.75	5.6	3.8	1.7	20.0
FDFD1.25-250	0.8x6.35	7.4	3.8	1.7	21.5

Сечение проводника: 1.5-2.5 мм²; Американский калибр: 16-14; Максимальный ток: I_{max}=15 А; Материал: латунь

Модель	Обозн. NEMA	Размеры (мм)			
		B	DØ	dØ	L
FDFD2-187(5)	0.5x4.75	5.6	4.3	2.3	20.0
FDFD2-187(8)	0.8x4.75	5.6	4.3	2.3	20.0
FDFD2-250	0.8x6.35	7.4	4.3	2.3	21.5

Сечение проводника: 4-6 мм²; Американский калибр: 12-10; Максимальный ток: I_{max}=24 А; Материал: латунь

Модель	Обозн. NEMA	Размеры (мм)			
		B	DØ	dØ	L
FDFD5-250	0.8x6.35	7.4	5.7	3.4	25.0

Разъединители с фиксатором и изоляцией

Сечение проводника: 0.5-1.5 мм²; Американский калибр: 22-16; Максимальный ток: I_{max}=10 А; Материал: латунь

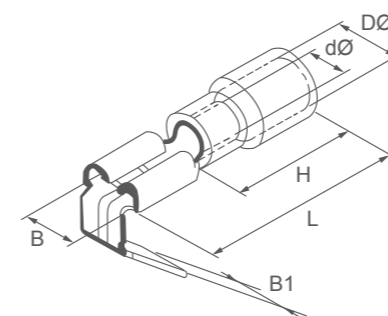
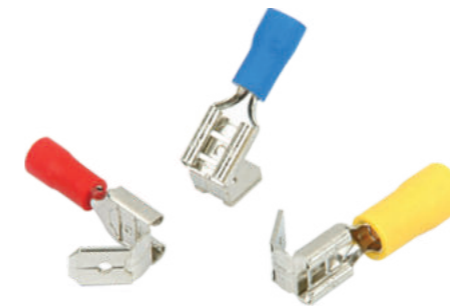

Модель	Обозн. NEMA	Размеры (мм)					
		B	B1	H	DØ	dØ	L
PBDD1.25-250	0.8x6.35	7.4	6.35	10.0	3.8	1.7	21.5

Сечение проводника: 1.5-2.5 мм²; Американский калибр: 16-14; Максимальный ток: I_{max}=15 А; Материал: латунь

Модель	Обозн. NEMA	Размеры (мм)					
		B	B1	H	DØ	dØ	L
PBDD2-250	0.8x6.35	7.4	6.3	10.0	4.3	2.3	21.5

Сечение проводника: 4-6 мм²; Американский калибр: 12-10; Максимальный ток: I_{max}=24А; Материал: латунь

Модель	Обозн. NEMA	Размеры (мм)					
		B	B1	H	DØ	dØ	L
PBDD5-250	0.8x6.35	7.4	6.35	13.0	5.7	3.4	25.0

Электрические аксессуары

Штырьевые контакты с изоляцией и без изоляции



Штырьевые контакты с изоляцией

Сечение проводника: 0.5-1.5 мм²; Американский калибр: 22-16;
Максимальный ток: I_{max}=19 A

Модель	Размеры (мм)				Цвет
	F	L	H	DØ	
PTV1.25-9	1.9	19.0	10.0	4.3	Красный
PTV1.25-10	1.9	20.0			
PTV1.25-12	1.9	22.0			
PTV1.25-13	1.9	23.0			
PTV1.25-18	1.9	28.0			

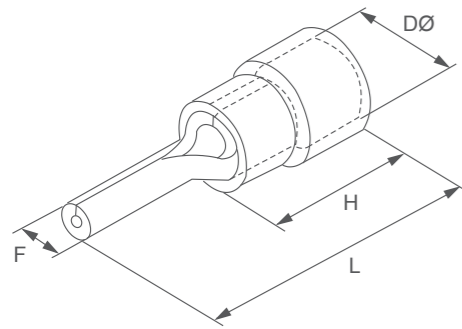

Сечение проводника: 1.5-2.5 мм²; Американский калибр: 16-14;
Максимальный ток: I_{max}=27 A

Модель	Размеры (мм)				Цвет
	F	L	H	DØ	
PTV2-9	1.9	19.0	10.0	4.9	Синий
PTV2-10	1.9	20.0			
PTV2-12	1.9	22.0			
PTV2-13	1.9	23.0			
PTV2-18	1.9	28.0			

Сечение проводника: 4-6 мм²; Американский калибр: 12-10;
Максимальный ток: I_{max}=48 A

Модель	Размеры (мм)				Цвет
	F	L	H	DØ	
PTV5.5-13	2.8	25.5	12.5	6.7	Желтый

Штырьевые контакты без изоляции

Сечение проводника: 0.5-1.5 мм²; Американский калибр: 22-16;
Максимальный ток: I_{max}=19 A



Модель	Размеры (мм)				
	F	L	E	DØ	dØ
PTN1.25-9	1.9	13.8	4.8	3.4	1.7
PTN1.25-10	1.9	14.8			
PTN1.25-12	1.9	16.8			
PTN1.25-13	1.9	17.8			
PTN1.25-18	1.9	22.8			

Сечение проводника: 1.5-2.5 мм²; Американский калибр: 16-14;
Максимальный ток: I_{max}=27 A

Модель	Размеры (мм)				
	F	L	E	DØ	dØ
PTN2-9	1.9	13.8	4.8	4.1	2.3
PTN2-10	1.9	14.8			
PTN2-12	1.9	16.8			
PTN2-13	1.9	17.8			
PTN2-18	1.9	22.8			

Сечение проводника: 1.5-2.5 мм²; Американский калибр: 22-16;
Максимальный ток: I_{max}=27 A

Модель	Размеры (мм)				
	F	L	E	DØ	dØ
PTN5.5-13	2.8	19.8	6.8	5.6	3.4

Электрические аксессуары

Плоские контакты с изоляцией и без изоляции



Плоские контакты с изоляцией

Сечение проводника: 0.5-1.5 мм²; Американский калибр: 22-16;
Максимальный ток: I_{max}=19 A; Материал: медь; Толщина материала: 0.75 мм

Модель	Размеры (мм)					Цвет
	B	L	F	H	DØ	
DBV1.25-10	2.3	20.0	10.0	10.0	4.3	Красный
DBV1.25-14	3.0	24.0	14.0			
DBV1.25-18	2.3	28.0	18.0			

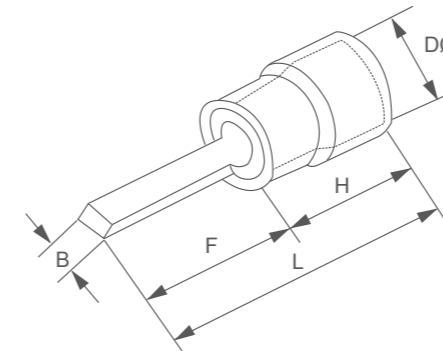

Сечение проводника: 1.5-2.5 мм²; Американский калибр: 16-14;
Максимальный ток: I_{max}=27 A; Материал: медь; Толщина материала: 0.8 мм

Модель	Размеры (мм)					Цвет
	B	L	F	H	DØ	
DBV2-10	2.4	19.0	9.0	10.0	4.9	Синий
DBV2-14	2.4	24.0	14.0			
DBV2-18	2.4	28.0	18.0			

Сечение проводника: 4-6 мм²; Американский калибр: 12-10;
Максимальный ток: I_{max}=48 A; Материал: медь; Толщина материала: 1.0 мм

Модель	Размеры (мм)					Цвет
	B	L	F	H	DØ	
DBV5.5-10	2.8	22.5	10.0	13.0	5.6	Желтый
DBV5.5-14	4.5	26.5	14.0			
DBV5.5-18	4.5	30.5	18.0			

Электрические аксессуары

Коннекторы кабеля с изоляцией



Предельная рабочая температура: 105°C, Ui=300В; Материал наконечника: медная трубка

Модель	Размеры							Сечение проводника мм ²	Цвет изоляции Сверху - Германия, снизу - Франция
	F	L	W	dØ	DØ	CØ	A.W.G		
E0506	6.0	12.0	12.0	2.6	1.3	1.0	#22	0.5	Оранжевый Белый
E0508	8.0	14.0	14.0						
E0510	10.0	16.0	16.0						
E7506	6.0	12.4	12.4	2.8	1.5	1.2	#20	0.75	Белый Синий
E7508	8.0	14.6	14.6						
E7510	10.0	16.4	16.4						
E7512	12.0	18.4	18.4	3.0	1.7	1.4	#18	1.0	Желтый Красный
E1006	6.0	12.4	12.4						
E1008	8.0	14.6	14.6						
E1010	10.0	16.4	16.4	3.5	2.0	1.7	#16	1.5	Красный Черный
E1012	12.0	18.4	18.4						
E1508	8.0	14.6	14.6						
E1510	10.0	16.4	16.4	4.0	2.6	2.3	#14	2.5	Синий Серый
E1518	18.0	24.4	24.4						
E2508	8.0	15.2	15.2						
E2512	12.0	19.0	19.0	4.4	3.2	2.8	#12	4.0	Серый Оранжевый
E2518	18.0	25.0	25.0						
E4009	9.0	16.5	16.5						
E4012	12.0	19.5	19.5	6.3	3.9	3.5	#10	6.0	Черный Зеленый
E4018	18.0	25.5	25.5						
E6012	12.0	20.0	20.0						
E6018	18.0	26.0	26.0	7.6	4.9	4.5	#7	10.0	Молочный Коричневый
E10-12	12.0	21.5	21.5						
E10-18	18.0	27.5	27.5						
E16-12	12.0	22.2	22.2	8.8	6.2	5.8	#5	16.0	Зеленый Молочный
E16-18	18.0	28.2	28.2						
E25-16	16.0	29.0	29.0						
E25-22	22.0	35.0	35.0	11.2	7.9	7.5	#4	25.0	Коричневый Черный
E35-16	16.0	30.0	30.0						
E35-25	25.0	39.0	39.0						
E50-20	20.0	36.0	36.0	12.7	8.7	8.3	#2	35.0	Грязно-коричневый
E50-25	25.0	41.0	41.0						
E50-25	25.0	41.0	41.0	15.3	10.9	10.3	#1	50.0	Оливковый
E50-25	25.0	41.0	41.0						

Электрические аксессуары

Клеммы для кабелей без изоляции

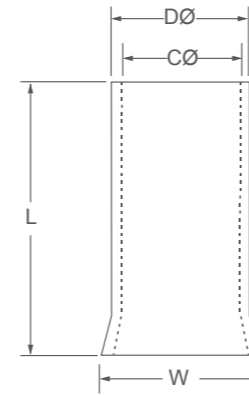

Клеммы для кабеля без изоляции

Предельная рабочая температура: 105 Ui=300В; Материал : медная трубка

Модель	Сечение проводника		Размеры (мм)			
	Амер. калиб.	мм ²	L	D	C	W
En0506	#22	0.5	6.0	1.3	1.0	2.1
EN1006	#18	1.0	6.0	1.7	1.4	2.7
EN1010	#18	1.0	10.0	1.7	1.4	2.7
EN1510	#16	1.5	10.0	2.0	1.7	3.5
EN2507	#14	2.5	7.0	2.5	2.2	2.5
EN2512	#14	2.5	12.0	2.5	2.2	2.5
EN4009	#12	4.0	9.0	3.2	2.8	4.0
EN4012	#12	4.0	12.0	3.2	2.8	4.0
EN6010	#10	6.0	10.0	3.9	3.5	4.8
EN6012	#10	6.0	12.0	3.9	3.5	4.8
EN6015	#10	6.0	15.0	3.9	3.5	4.8
EN10-12	#7	10.0	12.0	4.9	4.5	5.8
EN10-15	#7	10.0	15.0	4.9	4.5	5.8
EN10-15	#7	10.0	18.0	4.9	4.5	5.8
EN16-12	#5	16.0	12.0	6.2	5.8	7.5
EN16-15	#5	16.0	15.0	6.2	5.8	7.5
EN16-18	#5	16.0	18.0	6.2	5.8	7.5
EN25-16	#4	25.0	16.0	7.9	7.5	9.2
EN25-22	#4	25.0	22.0	7.9	7.5	9.2
EN35-16	#2	35.0	16.0	8.7	8.3	10
EN35-25	#2	35.0	25.0	8.7	8.3	10
EN50-20	#1	50.0	20.0	10.9	10.3	12.4

Двойные клеммы для кабеля без изоляции

Предельная рабочая температура: 105 Ui=300В; Материал : медная трубка

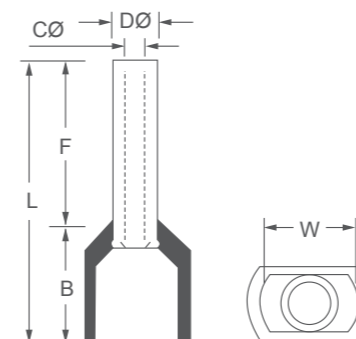
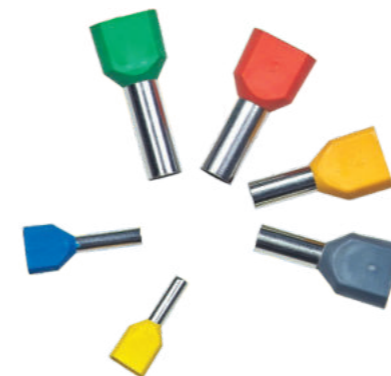

Модель	Обозн. NEMA	Размеры (мм)						Цвет	
		F	L	W	B	DØ	CØ	Германия	Франция
Te0508	2x0.5	8	14.5	8	6.5	1.8	1.5	Белый	Белый
TE7508	2x0.75	8	14.7	8	6.7	2.1	1.8	Синий	Серый
TE7510	2x0.75	10	16.7	10	6.7	2.1	1.8	Синий	Серый
TE1008	2x1.0	8	15.1	8	7.1	2.3	2.0	Красный	Красный
TE1010	2x1.0	10	17.1	10	7.1	2.3	2.0	Красный	Красный
TE1508	2x1.5	8	15.5	8	7.2	2.6	2.3	Черный	Желтый
TE1512	2x1.5	12	19.5	12	7.5	2.6	2.3	Черный	Желтый
TE2510	2x2.5	10	18.5	10	8.5	3.3	2.9	Серый	Синий
TE2512	2x2.5	13	21.5	13	8.5	3.3	2.9	Серый	Синий
TE4012	2x4.0	12	23.1	12	11.1	4.2	3.8	Оранжевый	Серый
TE6014	2x6.0	14	26.1	14	12.1	5.3	4.9	Зеленый	Желтый
TE10-14	2x10.0	14	26.6	14	12.0	6.9	6.5	Коричневый	Красный
TE16-14	2x16.0	14	31.3	8.9	17.3	8.7	8.3	Молочный	Синий

Концевой зажим



JXB

Концевой зажим JXB

Тип	Тв. пров. (мм ²)	Мягк. пров. (мм ²)	Мягк. пров. с трубкой (мм)	Ном. ток (А)	Ном. напр. (В)	Размеры (мм)
JXB-2.5/35	0.5-6	1.5-4	0.5-2.5	24	800	6×40×38.5
JXB-4/35	0.5-6	1.5-4	0.5-4	32	800	65×42×52
JXB-6/35	0.5-10	1.5-10	0.5-6	41	800	8×42×52
JXB-10/35	1.5-16	1.5-16	0.5-10	57	800	10×42×52
JXB-16/35	2.5-16	2.5-16	4-16	76	800	12×42×52
JXB-35/35	6-35	10-35	10-35	125	800	18×50×63.5
JXB-70/35	10-70	10-70	10-70	192	800	22×75×87

Концевой зажим ЕК

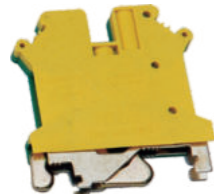

Тип	Тв. пров. (мм ²)	Мягк. пров. (мм ²)	Мягк. пров. с трубкой (мм)	Размеры (мм)
EK-2.5/35	0.5-14	1.5-2.5	0.5-2.5	6×57×37
EK-4/35	0.5-6	1.5-4	0.5-4	8×57×41
EK-6/35	0.5-10	1.5-6	0.5-6	12×57×48
EK-10/35	0.5-16	1.5-10	0.5-10	10×57×48
EK-16/35	2.5-16	2.5-16	4-16	12×57×48

Концевой зажим УК

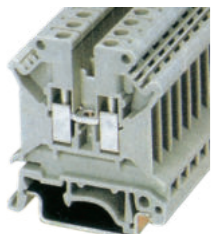

UK Baffle

Тип	Тв. пров. (мм ²)	Мягк. пров. (мм ²)	Ном. ток (А)	Ном. напряж. (В)	Размеры (мм)
УК-1.5N	0.14-1.5	0.14-1.5	17.5	660	4.2×42.5×40.5
УК-2.5B	1.0-4	1.0-2.5	32	800	62×42.5×42
УК-3N	0.2-6	0.2-4	32	800	5.2×42.5×47
УК-5N	0.2-6	0.2-4	41	800	6.2×42.5×47
УК-6N	0.5-10	0.5-6	57	800	8.2×42×47
УК-10N	0.5-16	1.5-10	76	800	10.2×42.5×47
УК-16N	2.5-25	4-16	101	800	12.2×42.5×54
УК-35N	0.75-50	0.75-35	125	1000	15.2×50.5×61
УКН-50	16-50	25-50	150	1000	20×70.5×83.5
УКН-95	25-95	35-95	232	1000	25×83.2×97.5
УКН-150	35-150	50-150	309	1000	32×100×118
УКН-240	70-240	70-240	415	1000	36×100×131.5

Концевой зажим USLKG

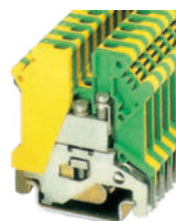
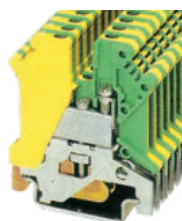

Тип	Тв. пров. (мм ²)	Мягк. пров. (мм ²)	Ном. ток (А)	Ном. напряж. (В)	Размеры (мм)
USLKG1.5N	0.14-1.5	0.14-1.5	12	660	6.2×42.5×47
USLKG2.5	0.2-4	0.2-2.5	32	800	6.2×42.5×47
USLKG3	0.25-2.5	0.25-1.5	32	800	5.2×42.5×47
USLKG5	0.25-4	0.25-2.5	41	800	6.2×42.5×47
USLKG6N	0.25-6	0.25-6	57	800	8.2×42.5×47
USLKG10N	0.5-16	0.5-10	76	800	10.2×42.5×47
USLKG16N	2.5-25	4-16	101		12.2×42.5×54
USLKG35	0.75-50	0.75-35	150		15.2×50.5×62
USLKG50	16-50	25-50	150		20×70.5×81.5

Концевой зажим

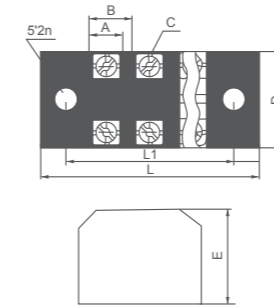
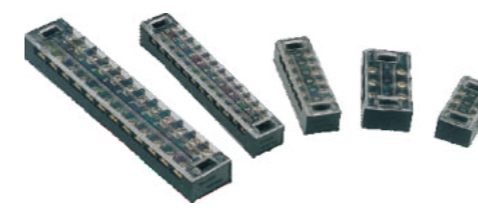

Концевой зажим ТВ

Тип	Ток (А)	Кол-во пол.	Размеры						
			L	L1	A	B	C	D	E
TB-1503	15	3	46	36.5	7.5	9	M3	22	17
TB-1504	15	4	55	45.5	7.5	9	M3	22	17
TB-1506	15	6	73	63.5	7.5	9	M3	22	17
TB-1512	15	12	127	118	7.5	9	M3	22	17
TB-2503	25	3	50	40	10.5	12	M4	30	20
TB-2504	25	4	62.5	57	10.5	12	M4	30	20
TB-2506	25	6	91	81.5	10.5	12	M4	30	20
TB-2512	25	12	163	153	10.5	12	M4	30	20
TB-3503	35	3	50	40	10.5	12	M4	30	20
TB-3504	35	4	62.5	57	10.5	12	M4	30	20
TB-3506	35	6	91	81.5	10.5	12	M4	30	20
TB-3512	35	12	163	153	10.5	12	M4	30	20
TB-4503	45	3	70	60.5	15	17	M5	38	23.5
TB-4504	45	4	86	75.5	15	17	M5	38	23.5
TB-4506	45	6	120.5	110	15	17	M5	38	23.5
TB-6003	60	3	70.5	65.5	15.5	18	M6	38	31
TB-6004	60	4	93.5	82.5	15.5	18	M6	38	31
TB-6006	60	6	129	118	15.5	18	M6	38	31
TB-1003	100	3	86.5	75.5	22	20	M6	43.5	35
TB-1004	100	4	108	96	22	20	M6	43.5	35
TB-1006	100	6	153	140	22	20	M6	43.5	35

Концевой зажим ТС

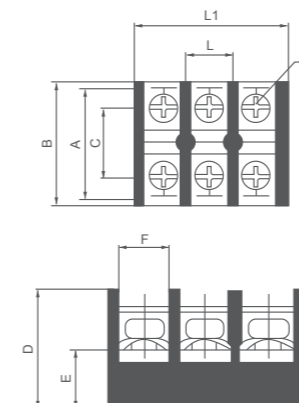

Тип	Ток (А)	Кол-во пол.	Размеры								
			L	L1	A	B	C	D	E	F	G
ТС-603	60	3	28.5	86.5	38	42.7	25.5	31	15	17	M6
ТС-604	60	4	28.5	115	38	42.7	25.5	31	15	17	M6
ТС-1003	100	3	34.5	113.5	46.5	55.2	28	36.3	17.3	22.5	M6
ТС-1004	100	4	34.5	137.5	46.5	55.2	28	36.3	17.3	22.5	M6
ТС-1503	150	3	38.5	115	57.2	67	30.5	40	19.8	25.3	M8
ТС-1504	150	4	38.5	153	57.2	67	30.5	40	19.8	25.3	M8
ТС-2003	200	3	44.5	133	63	72.1	34	44.4	23	28.3	M8
ТС-2004	200	4	44.5	177	63	72.1	34	44.4	23	28.3	M8
ТС-3003	300	3	55	164	78	89.4	47.5	50.6	27	30	M10
ТС-3004	300	4	55	218	78	89.4	47.5	50.6	27	30	M10
ТС-4003	400	3	55	164	78	89.4	47.5	50.6	27	36	M10
ТС-4004	400	4	55	218	78	89.4	47.5	50.6	27	36	M10

Электрические аксессуары

Охлаждающий вентилятор



Размеры: 80×80×25 мм
 Расход: 24-39 м³/ч
 Масса: 208 г
 Уровень шума: 22-30 дБА
 Рабочая температура: -10...+65°C

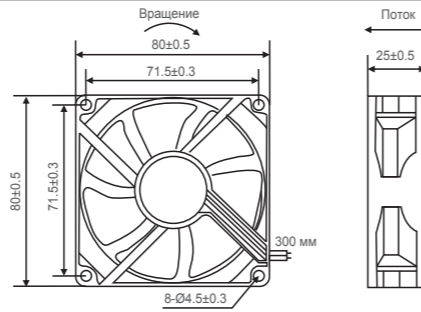

Технические характеристики

Тип	Подшипник	Напряж. (В)	Частота (Гц)	Ток (А)	Мощн. (Вт)	Част. вращ. (об/мин)	Шум (дБА)	Расход м³/ч
УС8025-1	Неразбор.	110	50/60	0.13	13	2300/2600	27/30	32/39
УС8025-2		220		0.07				
УС8025-3	Шариковый	110		0.13				
УС8025-4		220		0.07				



Размеры: 92×92×25мм
 Расход: 37-58 м³/ч
 Масса: 268 г
 Уровень шума: 28-40 дБА
 Рабочая температура: -10...+65°C

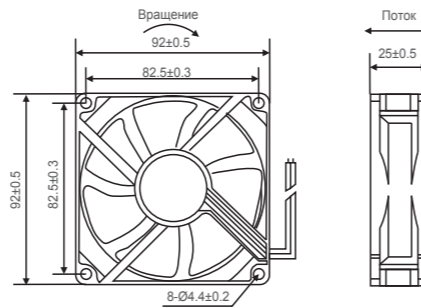

Технические характеристики

Тип	Подшипник	Напряж. (В)	Частота (Гц)	Ток (А)	Мощн. (Вт)	Част. вращ. (об/мин)	Шум (дБА)	Расход м³/ч
УС9225-1	Неразбор.	110	50/60	0.14	13	2300/2600	34/40	47/58
УС9225-2		220		0.07				
УС9225-3	Шариковый	110		0.14				
УС9225-4		220		0.07				



Размеры: 110×110×25 мм
 Расход: 70-100 м³/ч
 Масса: 304 г
 Уровень шума: 30-41 дБА
 Рабочая температура: -10...+65°C

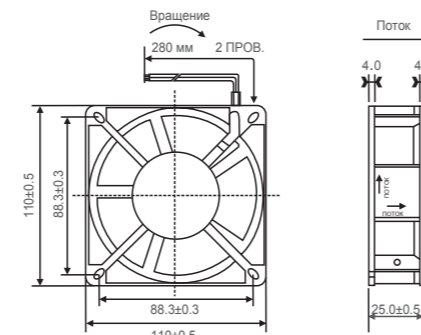

Технические характеристики

Тип	Подшипник	Напряж. (В)	Частота (Гц)	Ток (А)	Мощн. (Вт)	Част. вращ. (об/мин)	Шум (дБА)	Расход м³/ч
УС11025-1	Неразборный	110	50/60	0.20	18	2300/2600	35/41	35/41
УС11025-2		220		0.10				
УС11025-3	Шариковый	110		0.20				
УС11025-4		220		0.10				

Электрические аксессуары

Охлаждающий вентилятор



Размеры: 120×120×25 мм
 Расход: 76-112 м³/ч
 Масса: 314 г
 Уровень шума: 31-42 дБА
 Рабочая температура: -10...+65°C

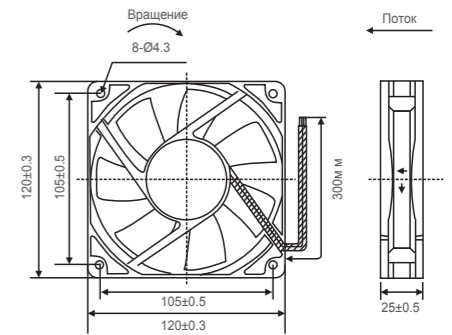

Технические характеристики

Тип	Подшипник	Напряж. (В)	Частота (Гц)	Ток (А)	Мощн. (Вт)	Част. вращ. (об/мин)	Шум (дБА)	Расход м³/ч
УС12025-1	Неразборн.	110	50/60	0.20	18	2300/2600	39/42	96/112
УС12025-2		220		0.10				
УС12025-3	Шариковый	110		0.20				
УС12025-4		220		0.10				



Размеры: 120×120×38 мм
 Расход: 134-204 м³/ч
 Масса: 600 г
 Уровень шума: 39-50 дБА
 Рабочая температура: -10...+105°C

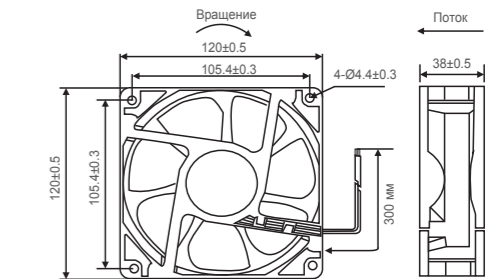

Технические характеристики

Тип	Подшипник	Напряж. (В)	Частота (Гц)	Ток (А)	Мощн. (Вт)	Част. вращ. (об/мин)	Шум (дБА)	Расход м³/ч
УС12038-1	Неразборн.	110	50/60	0.25	24	2300/2600	45/50	180/204
УС12038-2		220		0.14	22			
УС12038-3	380	0.09		22				
УС12038-4	Шариковый	110		0.25	24			
УС12038-5		220		0.14	22			
УС12038-6	380	0.09		22				

Электрические аксессуары

Охлаждающий вентилятор



Размеры: 135×135×32 мм
 Расход: 156-197 м³/ч
 Масса: 595 г
 Уровень шума: 44-50 дБА
 Рабочая температура: -10...+65°C

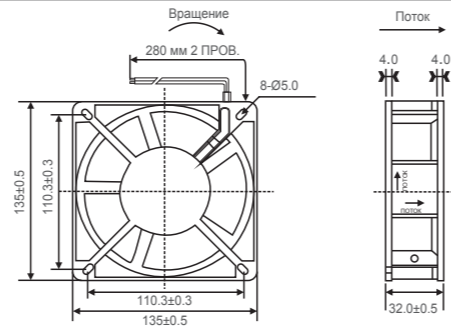

Технические характеристики

Тип	Подшип.	Напряж. (В)	Частота (Гц)	Ток (А)	Мощн. (Вт)	Част. вращ. (об/мин)	Шум (дБА)	Расход м³/ч
YC125FZY1-S	Неразб.	110	50/60	0.34	25	2400/2800	44/50	156/197
YC125FZY2-S		220		0.17				
YC125FZY3-S		380		0.10				



Размеры: 135×135×38 мм
 Расход: 141-205 м³/ч
 Масса: 555 г
 Уровень шума: 41-53 дБА
 Рабочая температура: -10...+105°C

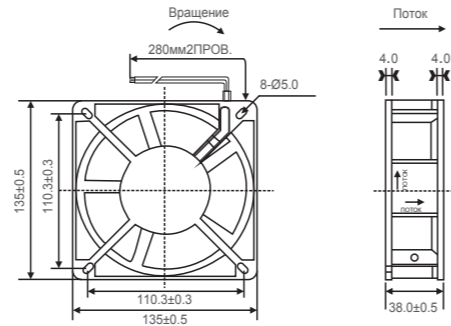

Технические характеристики

Тип	Подшип.	Напряж. (В)	Частота (Гц)	Ток (А)	Мощн. (Вт)	Част. вращ. (об/мин)	Шум (дБА)	Расход м³/ч
YC13538-1	Неразб.	220	50/60	0.18	25	2400/2800	46/53	165/205
YC13538-2		380		0.11				
YC13538-3	Шарик.	220		0.18				



Размеры: 172×150×39 мм
 Расход: 330-375 м³/ч
 Масса: 655 г
 Уровень шума: 56-60 дБА
 Рабочая температура: -10...+70°C

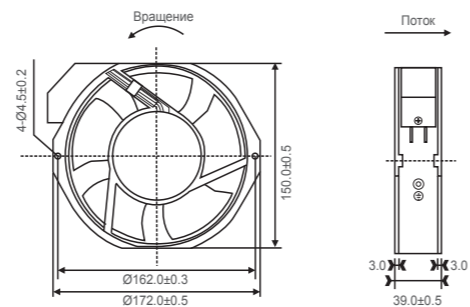

Технические характеристики

Тип	Подшипник	Напряж. (В)	Частота (Гц)	Ток (А)	Мощность (Вт)	Част. вращ. (об/мин)	Шум (дБА)	Расход м³/ч	Конденсатор
YC145FZY1-S	Шариковый	110	50/60	0.36	30	2400/2800	56	330/375	3.3мкф/250В
YC145FZY2-S		220		0.18					1.0мкф/500В
YC145FZY3-S		380		0.10	25				0.47мкф/630В

Электрические аксессуары

Охлаждающий вентилятор



Размеры: 150×150×50 мм
 Расход: 373-501 м³/ч
 Масса: 1200 г
 Уровень шума: 50-59 дБА
 Рабочая температура: -10...+65°C

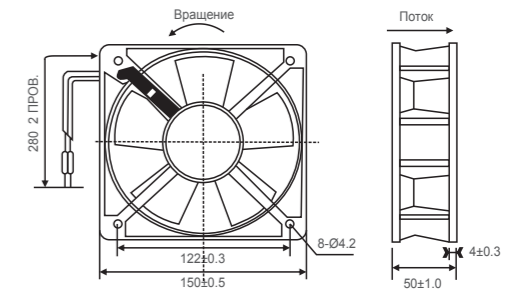

Технические характеристики

Тип	Подшип.	Напряж. (В)	Частота (Гц)	Ток (А)	Мощн. (Вт)	Част. вращ. (об/мин)	Шум (дБА)	Расход м³/ч
YC15050-1	Неразб.	110	50/60	0.40	38	2300/2600	54/59	299/336
YC15050-2		220		0.22				
YC15050-3		380		0.12				
YC15050-4	Шарик.	220		0.22			49/54	
YC15050-5		380	0.12					



Размеры: 172×150×50 мм
 Расход: 330-375 м³/ч
 Масса: 655 г
 Уровень шума: 56-60 дБА
 Рабочая температура: -10...+70°C

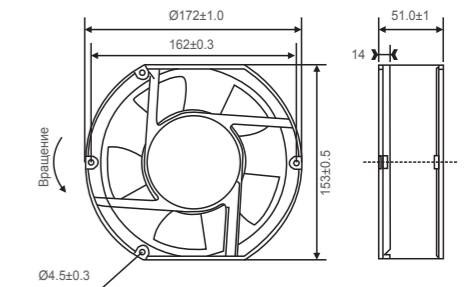

Технические характеристики

Тип	Подшип.	Напряж. (В)	Частота (Гц)	Ток (А)	Мощн. (Вт)	Част. вращ. (об/мин)	Шум (дБА)	Расход м³/ч
YC17251-1	Неразб.	110	50/60	0.40	38	2300/2600	54/59	299/336
YC17251-2		220		0.22				
YC17251-3		380		0.12				
YC17251-4	Шарик.	220		0.22			49/54	
YC17251-5		380	0.12					

Электрические аксессуары

Охлаждающий вентилятор



Размеры: 172×172×50 мм
 Расход: 373-501 м³/ч
 Масса: 1200 г
 Уровень шума: 50-59 дБА
 Рабочая температура: -10...+65°C

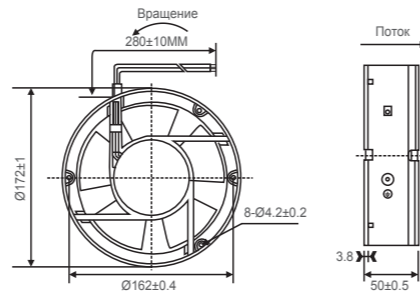

Технические характеристики

Тип	Подшип.	Напряж. (В)	Частота (Гц)	Ток (А)	Мощн. (Вт)	Част. вращ. (об/мин)	Шум (дБА)	Расход м³/ч
УС17252-1	Неразб.	110	50/60	0.40	38	2300/2600	54/59	299/336
УС17252-2		220		0.22				
УС17252-3	Шарик.	380	50/60	0.12	38	2300/2600	49/54	299/336
УС17252-4		220		0.22				
УС17252-5		380		0.12				

Электрические аксессуары

Охлаждающий вентилятор



Размеры: 220×220×60 мм
 Расход: 612-7901 м³/ч
 Масса: 1600 г
 Уровень шума: 56-68 дБА
 Рабочая температура: -10...+65°C

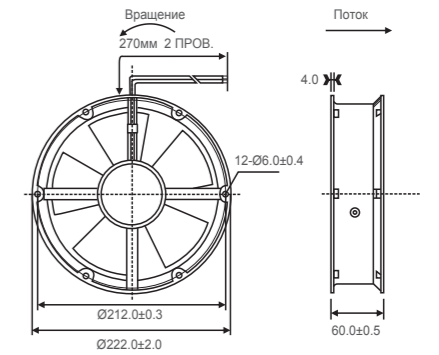

Технические характеристики

Тип	Подшип.	Напряж. (В)	Частота (Гц)	Ток (А)	Мощн. (Вт)	Част. вращ. (об/мин)	Шум (дБА)	Расход м³/ч
УС22060-1	Шарик.	220	50/60	0.48	65	2600	70	586/671
УС22060-2		380		0.30				



Размеры: 180×180×60 мм
 Расход: 86-671 м³/ч
 Масса: 1200 г
 Уровень шума: 50-59 дБА
 Рабочая температура: -10...+65°C

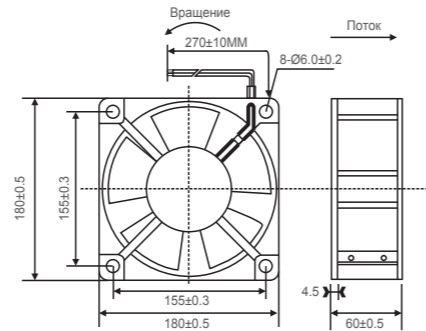

Технические характеристики

Тип	Подшип.	Напряж. (В)	Частота (Гц)	Ток (А)	Мощн. (Вт)	Част. вращ. (об/мин)	Шум (дБА)	Расход м³/ч
УС18060-1	Шарик.	220	50/60	0.23	55	2400/2700	63/68	586/671
УС18060-2		380		0.13				



Размеры: 225×225×80 мм
 Расход: 612-7901 м³/ч
 Масса: 2200 г
 Уровень шума: 56-68 дБА
 Рабочая температура: -10...+105°C

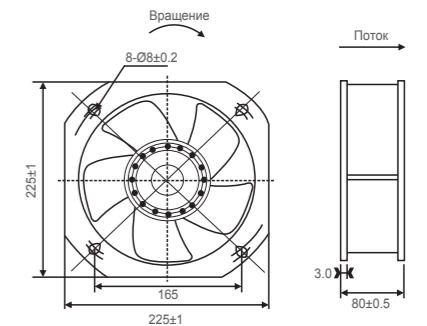

Технические характеристики

Тип	Подшип.	Напряж. (В)	Частота (Гц)	Ток (А)	Мощн. (Вт)	Част. вращ. (об/мин)	Шум (дБА)	Расход м³/ч	Фазы	Конденс.
УС200FZY1-S	Шариковый	220	50/60	0.42	85	2500/2850	63/66	1050/1290	1	2мкФ/500В
УС200FZY2-S		380		0.28					3	/
УС200FZY3-S		380		0.32					1	1.5мкФ/630В



Размеры: 200×200×60 мм
 Расход: 660-760 м³/ч
 Масса: 1600 г
 Шум: 63-68 дБА
 Рабочая температура: -10...+65°C

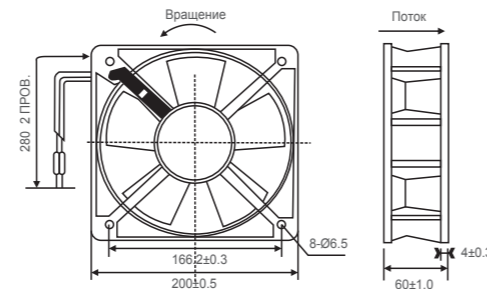

Технические характеристики

Тип	Подшип.	Напряж. (В)	Частота (Гц)	Ток (А)	Мощн. (Вт)	Част. вращ. (об/мин)	Шум (дБА)	Расход м³/ч
УС20060-1	Шарик.	220	50/60	0.48	65	2600	70	586/671
УС20060-2		380		0.30				

Электрические аксессуары

Нейлоновый кабельный ввод PG



Общая информация

1. Модель: PG
2. Материал: компоненты А, С, Е изготовлены из нейлона PA66, компоненты В и D изготовлены из бутадиен-нитрильного каучука (NBR).
3. Рабочая температура: от -40 до +100 °С в статическом состоянии, кратковременно до +120 °С; от -20 до +80 °С в динамическом состоянии, кратковременно до +100 °С.
4. Характеристики: специальная конструкция зажима и резиновой части, большой диапазон совместимых кабелей, сверхвысокая устойчивость к растяжению, водонепроницаемость, пылезащита, высокая стойкость к соли, кислоте, щелочи, спирту, смазке и общим растворителям.

Выбор цвета



Чертеж конструкции

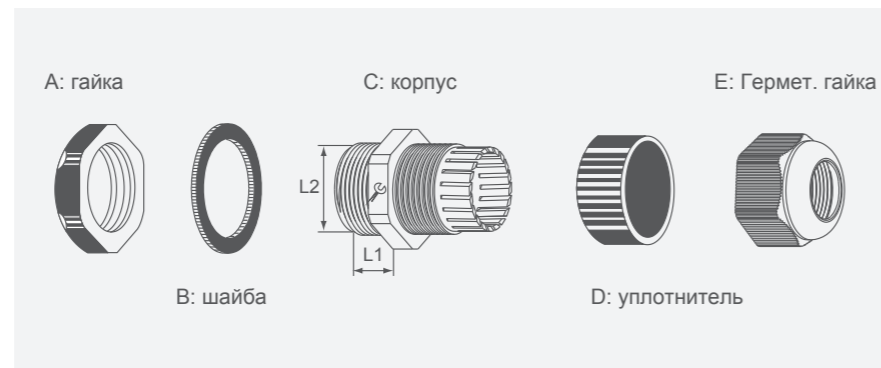

Технические характеристики

Модель	Резьба	Диам. кабеля (мм)	Нар. диаметр резьбы L2(мм)	Длина резьбы L1(мм)	Размер ключа А и Е (мм)
PG7	PG7	3-6.5	12.5	9	18/16
PG9	PG9	4-8	15.2	9	22/19
PG11	PG11	5-10	18.6	9	24/22
PG13.5	PG13.5	6-11	20.4	10	27/24
PG16	PG16	10-13	22.5	10	30/27
PG19	PG19	12-15	24	10	30/28
PG21	PG21	13-18	28.3	12	35/33
PG25	PG25	16-21	30	12	37/35
PG29	PG29	18-25	37	12	45/42
PG36	PG36	22-32	47	15	58/52
PG42	PG42	32-38	54	18	62/58
PG48	PG48	37-44	59.3	18	70/64
PG63	PG63	42-50	71	30	83/77

Электрические аксессуары

Самофиксирующиеся нейлоновые кабельные стяжки



Самофиксирующиеся нейлоновые кабельные стяжки

Материал: нейлон 66, 94V-2, сертифицированный UL. Теплостойкость, защита от эрозии, хорошая теплоизоляция и устойчивость к старению.

Цвет: натуральный (или белый, стандартный цвет), черный и другие цвета доступны по запросу.

Тип	Длина мм	Ширина (мм)	Максимальн. диаметр (мм)	Мин. прочность на растяжение кгс	Упаковка
3×60	60	2.5	11	8	100 шт и 1000 шт
3×80	80	2.5	16	8	
3×100	100	2.5	23	8	
3×120	120	2.5	27	8	
3×150	150	2.5	36	8	
3×160	160	2.5	39	8	100 шт и 500 шт
3×200	200	2.5	50	8	
4×100	100	3.6	21	18	
4×120	120	3.6	27	18	
4×150	150	3.6	38	18	
4×180	180	3.6	46	18	100 шт и 250 шт
4×200	200	3.6	52	18	
4×250	250	3.6	65	18	
4×300	300	3.6	80	18	
4×370	370	3.6	100	18	
5×100	100	4.8	23	22	100 шт и 250 шт
5×120	120	4.8	27	22	
5×160	160	4.8	38	22	
5×185	185	4.8	42	22	
5×200	200	4.8	50	22	
5×250	250	4.8	65	22	
5×280	280	4.8	70	20	
5×300	300	4.8	82	22	
5×350	350	4.8	98	22	
5×370	370	4.8	105	22	
5×400	400	4.8	115	22	
5×430	430	4.8	125	22	
5×450	450	4.8	132	22	
5×500	500	4.8	148	22	
5×530	530	4.8	155	22	
8×150	150	7.6	35	53	100 шт и 250 шт
8×200	200	7.6	50	53	
8×250	250	7.6	66	53	
8×300	300	7.6	82	53	
8×350	350	7.6	98	53	
8×370	370	7.6	105	53	
8×400	400	7.6	114	53	
8×450	450	7.6	130	53	
8×500	500	7.6	146	53	
8×550	550	7.6	160	53	
10×400	400	8.8	114	80	100 шт
10×450	450	8.8	126	80	
10×500	500	8.8	140	80	
10×550	550	8.8	160	80	
10×610	610	8.8	178	80	
10×650	650	8.8	190	80	
10×760	760	8.8	226	80	
10×810	810	8.8	241	80	
10×920	920	8.8	276	80	
10×1020	1020	8.8	295	80	
10×1200	1200	8.8	345	80	100 шт
12×650	650	11	190	114	
12×760	760	11	226	114	

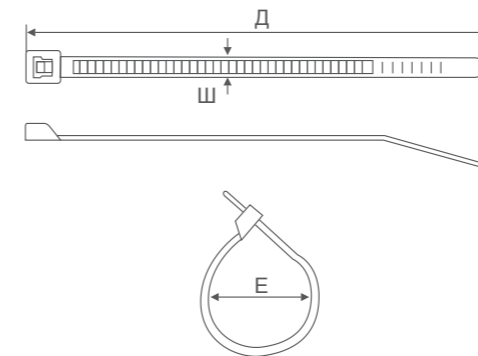

Клеммные колодки



Клеммные колодки

Тип: NU (W), V (F)

Материалы: полиамид, полиэтилен, полипропилен.

Тип	L (мм)	W (мм)	H (мм)	A (мм)	B (мм)	Сеч. мм ²	Напр.	Ток	Упаковка
X3-03A	93	16	12	6	8	4	400 В	3 А	10 шт
X3-06A	115	15.7	13	6.5	9.5	6	400 В	6 А	
X3-10A	126	20.2	15.5	8.4	10.5	10	400 В	10 А	
X3-16A	139	23	17.7	10.3	12	12	400 В	16 А	
X3-20A	155	25	19.2	11.5	13.5	14	400 В	20 А	
X3-30A	171	26	20.5	12	14.5	16	400 В	30 А	
X3-60A	192	30	26	13.5	16.5	25	400 В	60 А	
X3-80A	205	33	27	15	17	35	400 В	80 А	
X3-100A	250	46	31	22	21	40	400 В	100 А	

Распределительный изолятор

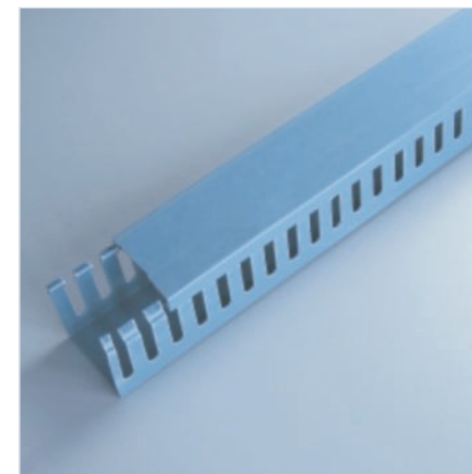

Распределительный изолятор

Материал: ПВХ (серого цвета), хорошая теплоизоляция и термостойкость до +85°C.

Конструкция: состоит из дна и крышки с двумя выходными отверстиями в нижней части.

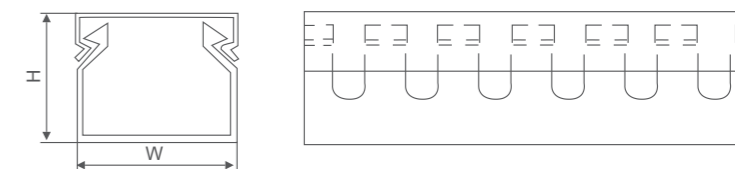

Тип	Размеры, Н×W (мм)	Проводники (2.0 ²)	Длина
2015	20×15	5-10 шт	2 м
2525	25×25	10-20 шт	2 м
3015	30×15	5-15 шт	2 м
3020	30×20	10-20 шт	2 м
3025	30×25	15-25 шт	2 м
3030	30×30	20-40 шт	2 м
3035	30×35	30-45 шт	2 м
3535	35×35	35-50 шт	2 м
4025	40×25	20-25 шт	2 м
4030	40×30	35-45 шт	2 м
4040	40×40	60-70 шт	2 м
5025	50×25	25-45 шт	2 м
5030	50×30	30-50 шт	2 м
5035	50×35	50-60 шт	2 м
5040	50×40	60-70 шт	2 м
5045	50×45	70-80 шт	2 м
5050	50×50	80-90 шт	2 м
5055	50×55	100-110 шт	2 м
5080	50×80	180-200 шт	2 м
50100	50×100	210-260 шт	2 м
8045	80×45	160-180 шт	2 м
8050	80×50	180-200 шт	2 м
8055	80×55	180-210 шт	2 м
8080	80×80	240-290 шт	2 м
80100	80×100	260-350 шт	2 м
100100	100×100	300-400 шт	2 м

Электрические аксессуары

Огнестойкая термоусадочная трубка

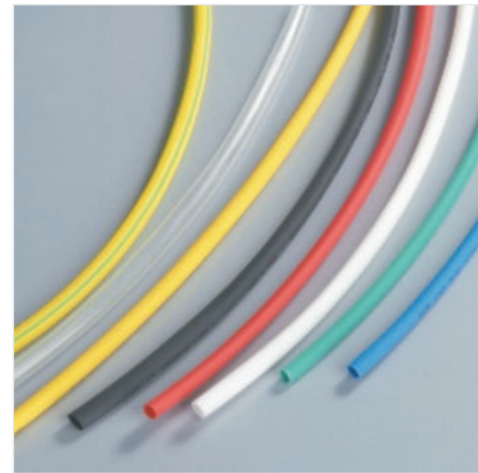

Общая информация

Огнестойкая термоусадочная трубка отличается высокой гибкостью, хорошими показателями усадки и мягкостью при низких температурах. Термоусадочная трубка широко используется для защиты соединений проводов, маркировки проводов, изоляционной защиты резисторов и конденсаторов, защиты от коррозии и защиты антенн.

Термоусадочная трубка под воздействием высокой температуры образует прочную изолирующую оболочку, стойкую к воздействиям температур, кислот, щелочей, химических веществ.

Цвет: черный, красный, синий, белый, желтый, зеленый, прозрачный. По заказу также доступны другие цвета.

Коэффициент сжатия: 2:1.

Номинальное напряжение: 600 В.

Спецификация	Размеры до усадки (мм)		Размеры после усадки (мм)		Стандартная упаковка (м/диск)	Размеры провода (мм)
	Внутренний диаметр	Толщина стенки	Внутр. диаметр	Толщ. стенки		
Ø0.8	1.0±0.2	0.2±0.05	0.4±0.1	0.22±0.05	200	0.6-0.8
Ø1.0	1.4±0.3	0.2±0.05	0.4±0.1	0.28±0.05	200	0.75-0.9
Ø1.5	1.9±0.3	0.2±0.05	0.6±0.1	0.32±0.05	200	0.95-1.4
Ø2.0	2.4±0.3	0.25±0.05	0.9±0.1	0.35±0.05	200	1.1-1.8
Ø2.5	2.9±0.3	0.25±0.05	1.1±0.1	0.38±0.05	200	1.35-2.3
Ø3.0	3.4±0.4	0.25±0.05	1.4±0.1	0.40±0.05	200	1.6-2.7
Ø3.5	3.9±0.4	0.25±0.05	1.6±0.1	0.42±0.05	200	1.85-3.2
Ø4.0	4.5±0.4	0.25±0.05	1.8±0.1	0.45±0.05	200	2.1-3.6
Ø4.5	4.8±0.4	0.25±0.15	1.9±0.1	0.50±0.15	100	2.35-4.0
Ø5.0	5.4±0.4	0.25±0.15	2.3±0.1	0.55±0.15	100	2.6-4.5
Ø6.0	6.4±0.4	0.28±0.15	2.8±0.2	0.55±0.15	100	3.1-5.4
Ø7.0	7.4±0.4	0.28±0.15	3.3±0.2	0.55±0.15	100	3.7-3
Ø8.0	8.4±0.5	0.28±0.15	3.8±0.2	0.55±0.15	100	4.2-7.2
Ø9.0	9.4±0.5	0.30±0.15	4.3±0.2	0.55±0.15	100	4.7-8.0
Ø10	10.5±0.5	0.30±0.15	4.8±0.2	0.55±0.15	100	5.2-9.0
Ø11	11.5±0.5	0.30±0.15	5.3±0.2	0.60±0.15	100	5.7-10
Ø12	12.5±0.5	0.30±0.15	5.7±0.3	0.60±0.15	100	6.2-11
Ø13	13.5±0.5	0.33±0.15	6.2±0.3	0.60±0.15	100	6.7-2
Ø14	14.5±0.5	0.35±0.15	6.7±0.3	0.60±0.15	100	7.3-13
Ø15	15.5±0.6	0.38±0.15	7.2±0.3	0.65±0.15	100	7.8-14
Ø16	16.5±0.6	0.38±0.15	7.7±0.3	0.65±0.15	100	8.3-15
Ø17	17.5±0.6	0.38±0.15	8.2±0.3	0.65±0.15	100	8.8-16
Ø18	19.0±0.6	0.40±0.15	8.7±0.3	0.65±0.15	100	9.3-17
Ø20	21.0±0.8	0.40±0.20	9.7±0.3	0.75±0.20	100	10.4-19
Ø22	22.8±0.8	0.42±0.20	10.0±0.1	0.75±0.20	100	11.4-21
Ø25	25.8±0.8	0.45±0.20	11.0±0.1	0.75±0.20	50	12.8-24
Ø28	28.8±0.8	0.45±0.20	13.0±0.1	0.75±0.20	50	14.4-29
Ø30	30.8±0.8	0.45±0.20	14.0±0.1	0.75±0.20	50	16-29
Ø35	35.8±0.8	0.50±0.20	16.0±0.1	0.85±0.20	50	18-34
Ø40	42.0±1.0	0.50±0.20	19.0±0.1	0.85±0.20	50	21-39
Ø50	51.0±1.0	0.50±0.20	24.0±0.1	0.85±0.20	50	26-49
Ø60	61.0±1.0	0.65±0.20	29.0±0.1	0.85±0.20	25	35-55
Ø70	71.0±1.0	0.65±0.20	33.0±2.0	1.00±0.20	25	40-65
Ø80	81.0±1.0	0.65±0.20	37.0±2.0	1.00±0.20	25	45-75
Ø90	91.0±1.0	0.65±0.20	43.0±2.0	1.00±0.20	25	50-88
Ø100	102.0±2.0	0.65±0.20	48.0±2.0	1.00±0.20	25	55-95
Ø120	122.0±2.0	0.80±0.20	58.0±2.0	1.50±0.20	15	65-115
Ø150	152.0±2.0	0.80±0.20	73.0±2.0	1.50±0.20	15	80-145
Ø180	182.0±2.0	0.80±0.20	88.0±2.0	1.50±0.20	15	95-175

Электрические аксессуары

Термоусадочная трубка с двойной стенкой

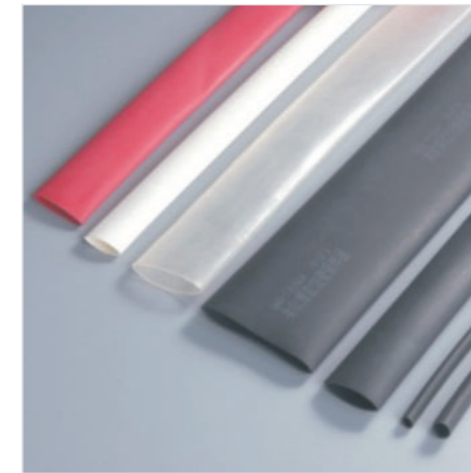

Общая информация

1. Данная термоусадочная трубка отличается наличием внутреннего термозольного слоя. Внешний слой состоит из специального ползитоизлена, а внутренний имеет специальную клейкую стенку. При нагревании внутренний термозоль прижимается к внешней стенке и заполняет зазор. При охлаждении образуется равномерная и очень прочная двойная стенка. Данная термоусадочная трубка широко используется для обеспечения водонепроницаемости и герметичности проводки электронного оборудования, герметизации ответвления проводки, защиты металлических проводов от ржавчины и восстановления проводов и кабелей. Термоусадка предотвращает ослабление различных полимерных соединений.

2. Рабочая температура: -55...+125°C;
Начальная температура усадки: +70°C;
Температура полной усадки: +125 °C;
Температура плавления внутреннего клеевого слоя: .70...+80°C

Коэффициент усадки: 3:1

Герметичность, водонепроницаемость, высокая гибкость, удобство использования, возможность усадки при нагревании в духовке или феном.

Стандартный цвет: черный (другие цвета по заказу).

Спецификация (мм)	Размеры до усадки (мм), внутренний диаметр	Размеры после усадки (мм)			Стандартная упаковка (м/диск)	Размеры провода (мм)
		Толщ. стенки	Толщ. стенки	Внутрен. диаметр		
Ø2.4	2.7±0.3	0.7±0.15	0.30±0.10	0.80	200	0.9-2.2
Ø3.2	3.5±0.3	0.90±0.15	0.35±0.10	1.00	200	1.2-3.1
Ø4.8	5.1±0.3	1.0±0.15	0.40±0.10	1.60	100	1.8-4.6
Ø6.4	6.8±0.4	1.2±0.15	0.45±0.12	2.20	100	2.4-6.4
Ø7.9	8.3±0.4	1.2±0.15	0.50±0.12	2.70	100	2.9-7.7
Ø9.5	9.9±0.4	1.4±0.15	0.50±0.12	3.20	1.22	3.4-9.4
Ø12.7	13.2±0.5	1.6±0.20	0.50±0.12	4.20	1.22	4.4-12.5
Ø15.0	15.5±0.5	1.8±0.20	0.55±0.12	5.20	1.22	5.4-14.8
Ø19.1	19.6±0.5	2.0±0.20	0.55±0.12	6.30	1.22	6.5-18.8
Ø25.4	26.2±0.8	2.1±0.20	0.55±0.15	8.50	1.22	8.8-25
Ø30.0	30.5±0.8	2.2±0.20	0.60±0.15	10.2	1.22	10.5-30
Ø39.0	39.8±0.8	2.4±0.20	0.60±0.15	13.5	1.22	14.0-39
Ø50.0	50.0±0.8	2.7±0.25	0.70±0.15	17.0	1.22	17.5-49
Ø64	≥64	3.0±0.25	0.70±0.15	21.0	1.22	22-62
Ø75	≥76	3.0±0.30	1.00±0.20	25.0	1.22	26-72
Ø90	≥90	3.0±0.30	1.00±0.20	30.0	1.22	32-88
Ø100	≥100	3.0±0.30	1.00±0.20	34.0	1.22	36-90
Ø120	≥125	3.0±0.30	1.00±0.20	42.0	1.22	44-125

Электрические аксессуары

Желто-зеленая термоусадочная трубка

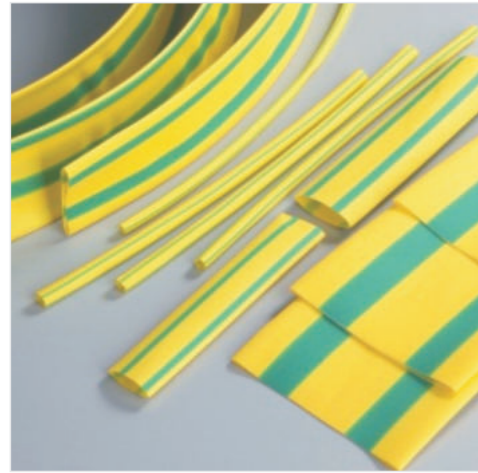

Общая информация

1. Трубка производится из высококачественных полиолефиновых материалов. Трубка отличается мягкостью, огнестойкостью, быстрой усадкой, ярким и стойким цветом, стабильными эксплуатационными характеристиками и широко используется для маркировки и изоляции проводников.
2. Температура эксплуатации: -55...+125°C;
Начальная температура усадки: +70 °C;
Температура полной усадки: +125 °C.
Мягкость, огнестойкость, яркий и стойкий цвет, удобство использования, возможность усадки при нагревании в духовке или феном.
Стандартный цвет: желто-зеленый.

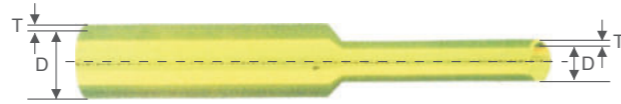

Параметр	Значение	Параметр	Значение
Температура эксплуатации	-55...+125°C	Затухание пламени	УСПЕШНО
Предел прочности	≥10.4 МПа	Прочность на разрыв	≥15 кВ/мм
Козф. продольной усадки	≤8%	Сопротивление	> 10 ¹⁴ Ом-см

Спецификация	Размеры до усадки (мм)		Размеры после усадки (мм)		Стандартная упаковка (м/диск)	Размеры провода (мм)
	Внутр. диаметр	Толщ. стенки	Макс. внутр. диаметр	Толщ. стенки		
Ø2.0	2.4±0.3	0.25±0.05	0.9±0.1	0.35±0.05	200	1.1-1.8
Ø3.0	3.4±0.4	0.25±0.05	1.4±0.1	0.40±0.05	200	1.6-2.7
Ø4.0	4.5±0.4	0.25±0.05	1.8±0.1	0.45±0.05	200	2.1-3.6
Ø5.0	5.4±0.4	0.25±0.15	2.3±0.1	0.55±0.15	100	2.6-4.5
Ø6.0	6.4±0.4	0.28±0.15	2.8±0.2	0.55±0.15	100	3.1-5.4
Ø7.0	7.4±0.4	0.28±0.15	3.3±0.2	0.55±0.15	100	3.7-6.3
Ø8.0	8.4±0.5	0.28±0.15	3.8±0.2	0.55±0.15	100	4.2-7.2
Ø10	10.5±0.5	0.30±0.15	4.8±0.2	0.55±0.15	100	5.2-9.0
Ø12	12.5±0.5	0.30±0.15	5.7±0.3	0.60±0.15	100	6.2-11
Ø14	14.5±0.5	0.35±0.15	6.7±0.3	0.60±0.15	100	7.3-13
Ø16	16.5±0.6	0.38±0.15	7.7±0.3	0.65±0.15	100	8.3-15
Ø0	21.0±0.8	0.40±0.15	9.7±0.3	0.75±0.15	100	10.4-19
Ø25	25.8±0.8	0.45±0.15	11.0±1.0	0.75±0.15	50	12.8-24
Ø30	30.8±0.8	0.45±0.15	14.0±1.0	0.75±0.15	50	16-29
Ø35	35.8±0.8	0.50±0.20	16.0±1.0	0.85±0.20	50	18-34
Ø40	42.0±1.0	0.50±0.20	19.0±1.0	0.85±0.20	50	21-39
Ø50	51.0±1.0	0.50±0.20	24.0±1.0	0.85±0.20	50	26-49
Ø60	61.0±1.0	0.65±0.20	29.0±1.0	0.85±0.20	25	35-55
Ø70	71.0±1.0	0.65±0.20	33.0±2.0	1.00±0.20	25	40-65
Ø80	81.0±1.0	0.65±0.20	37.0±2.0	1.00±0.20	25	45-75
Ø90	91.0±1.0	0.65±0.20	43.0±2.0	1.00±0.20	25	50-88
Ø100	102.0±2.0	0.65±0.20	48.0±2.0	1.00±0.20	25	55-95
Ø120	122.0±2.0	0.80±0.20	58.0±2.0	1.50±0.20	15	65-115
Ø150	152.0±2.0	0.80±0.20	73.0±2.0	1.50±0.20	15	80-145
Ø180	182.0±2.0	0.80±0.20	88.0±2.0	1.50±0.20	15	95-175

Электрические аксессуары

Спиральная лента, маркер кабеля



Спиральная лента

Материал: полиэтилен

Использование:

Сначала закрепите один конец ремнем, затем оберните провода по часовой стрелке таким образом, чтобы они стянулись.

Назначение:

Защита электрических проводов, изоляция, фиксация проводов.

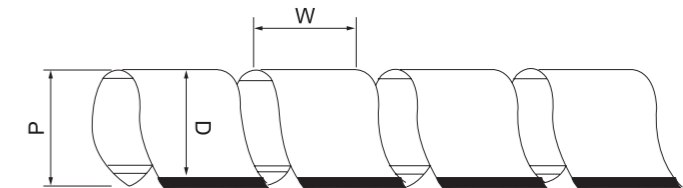

Тип	D (мм)	D1 (мм)	W (мм)	Диапазон (мм)	Упаковка
HD-6	4	6	7.0	4×50	10 м
HD-8	6	8	10.8	6×60	
HD-10	7.5	10	11.4	7.5×60	
HD-12	9	12	13.9	9×65	
HD-16	13	16	15.0	12×70	
HD-20	16	20	18.2	15×100	
HD-25	21	25	19.6	20×130	



Маркер кабеля

Материал:

ПВХ, защита от масла и эрозии, термостойкость до 85 °C.

Назначение:

Трубка внутри полая и эластичная, диаметр может меняться под нужный провод.

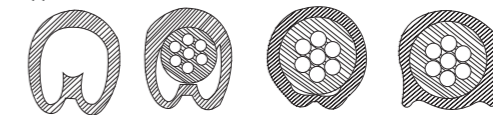

Тип	Приблизительный размер проводника		Маркеры	Упаковка
	кв.	мм		
EC-0	0.75-1.5	0.75-3.0	0-9 A-Z + - * / \	1000 шт
EC-1	2.5	2.6-4.2		1000 шт
EC-2	4	3.6-7.4		500 шт
EC-3	6	5.2-10		350 шт
	8	6.8		250 шт
	10	7.5		180 шт
EC-J	2-8	3.5-7		500 шт

Электрические аксессуары

Крепления для стяжек



Крепления для стяжек

Материал: нейлон 66, 94V-2, одобренный UL, с качественной клеевой накладкой.
Хорошая изоляция, долговечность, стойкость к старению.

Как использовать: снимите защитную пленку с клеевого слоя, приклейте площадку в нужном месте и вставьте в нее стяжку.

Назначение: используется в местах, где сверление отверстий для креплений невозможно. Позволяет значительно сэкономить время.

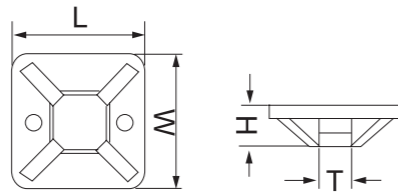

Тип	L×W (мм)	H (мм)	T (мм)	Упаковка
HDS-20	20×20	6.1	5	100 шт и 1000 шт
HDS-20	20×20	7.5	6.2	100 шт и 500 шт
HDS-30	30×30	8.7	6.4	100 шт и 500 шт
HDS-40	40×40	6.4	10.8	100 шт и 250 шт

Электрические аксессуары

Клеммная колодка

HC-001

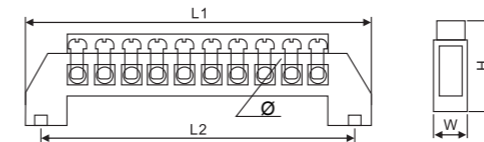
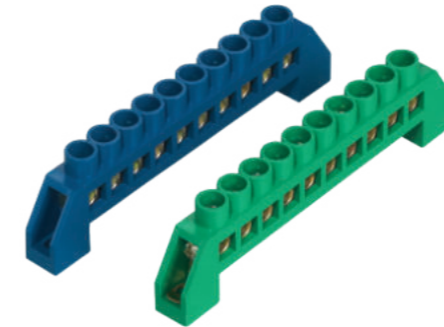

ПА, Полиамид марки 66,94-2. Замедлитель воспламенения.

Рабочая температура: от -30°C до +110°C.

АБС-пластик с хорошей защитой от ударов и воздействия химических веществ. Рабочая температура: от -20°C до +100°C.

Латунь. Винт — оцинкованная сталь.

Напряжение: 250-450 В.

Цвет: в соответствии с изображением образца или по индивидуальному заказу.

Кол-во конт.	Спец.	L	L1	L2	H	W	Ø	Винт	Пластик. вставка
	W×h								
4	6×9	36	59.5	48.5	29	11	6	M4×7	PA, ABS
6	6×9	53	76.5	65.5	29	11	6	M4×7	PA, ABS
8	6×9	70	93.5	82.5	29	11	6	M4×7	PA, ABS
10	6×9	87	110.5	99.5	29	11	6	M4×7	PA, ABS
12	6×9	105	127.5	116.5	29	11	6	M4×7	PA, ABS
4	8×12	44	59.5	48.5	32	12.5	7	M5×10	PA, ABS
6	8×12	54	76.5	65.5	32	12.5	7	M5×10	PA, ABS
8	8×12	71	93.5	82.5	32	12.5	7	M5×10	PA, ABS
10	8×12	87	110.5	99.5	32	12.5	7	M5×10	PA, ABS
12	8×12	105	127.5	116.5	32	12.5	7	M5×10	PA, ABS

HC-002

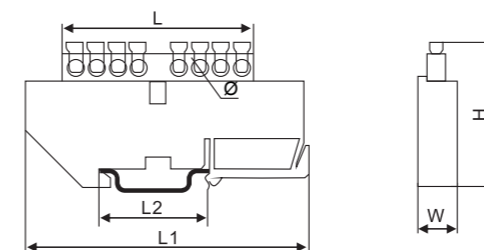
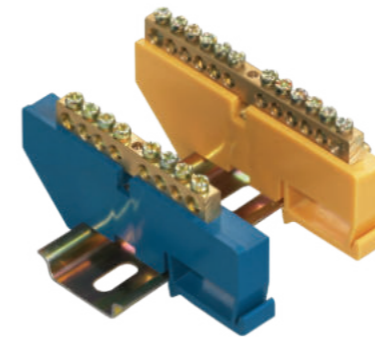

ПА, Полиамид марки 66,94-2. Замедлитель воспламенения.

Рабочая температура: от -30°C до +110°C.

АБС-пластик с хорошей защитой от ударов и воздействия химических веществ. Рабочая температура: от -20°C до +100°C.

Латунь. Винт — оцинкованная сталь.

Напряжение: 250-450 В.

Цвет: в соответствии с изображением образца или по индивидуальному заказу.

Кол-во конт.	Спец.	L	L1	L2	H	W	Ø	Винт	Пластик. вставка
	W×h								
8	6×9	60	90	35	43	12	5.2	M4×7	PA, ABS
10	6×9	73	90	35	43	12	5.2	M4×7	PA, ABS
12	6×9	86	90	35	43	12	5.2	M4×7	PA, ABS
14	6×9	99	90	35	43	12	5.2	M4×7	PA, ABS
8	8×12	71	90	35	46	12	6.5	M5×10	PA, PE
10	8×12	87	90	35	46	12	6.5	M5×10	PA, PE
12	8×12	103	103	35	46	12	6.5	M5×10	PA, PE
14	8×12	119	119	35	46	12	6.5	M5×10	PA, PE

Электрические аксессуары

Клеммная колодка

HC-003

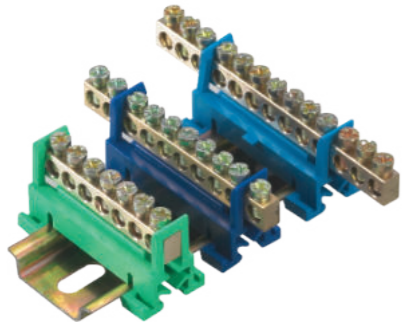

ПА, Полиамид марки 66,94-2. Замедлитель воспламенения.
Рабочая температура: от -30°C до +110°C.
АБС-пластик с хорошей защитой от ударов и воздействия химических веществ. Рабочая температура: от -20°C до +100°C.
Латунь. Винт — оцинкованная сталь.
Напряжение: 250-450 В.
Цвет: в соответствии с изображением образца или по индивидуальному заказу.

Кол-во конт.	Спец. Wxh	мм						Винт	Пластик. вставка
		L	L1	L2	H	W	Ø		
7	6×9	51	51	35	28	22	5.3	M5×8	ПА
8	6×9	59	59	35	28	22	5.3	M5×8	ПА
10	6×9	72	72	35	28	22	5.3	M5×8	ПА
12	6×9	85	85	35	28	22	5.3	M5×8	ПА

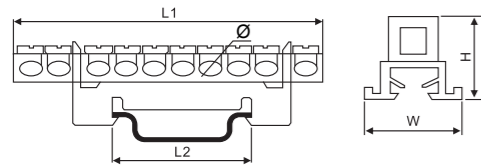

HC-004

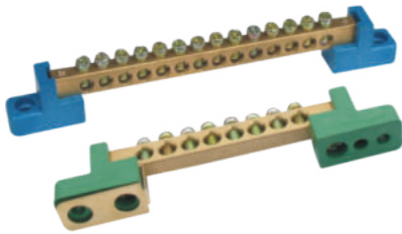

ПА, Полиамид марки 66,94-2. Замедлитель воспламенения.
Рабочая температура: от -30°C до +110°C.
АБС-пластик с хорошей защитой от ударов и воздействия химических веществ. Рабочая температура: от -20°C до +70°C.
РЕ, полипропилен, замедление воспламенения, низкая прозрачность, низкая жесткость, хорошая стойкость к ударам. Рабочая температура: от -30°C до +110°C.
Латунь. Винт — оцинкованная сталь.
Напряжение: 250-450 В.
Цвет: в соответствии с изображением образца или по индивидуальному заказу.

Кол-во конт.	Спец. Wxh	мм						Винт	Пластик. вставка
		L	L1	L2	H	W	Ø		
6	6×9	53.5	85	72.5	22	12.5	5	M4×7	ABS, PE
7	6×9	60	91.5	79	22	12.5	5	M4×7	ABS, PE
8	6×9	66.5	98	85.5	22	12.5	5	M4×7	ABS, PE
10	6×9	79.5	111	98.5	22	12.5	5	M4×7	ABS, PE
12	6×9	92.5	124	111.5	22	12.5	5	M4×7	ABS, PE
6	8×12	66.5	95.5	82.5	26	12.5	6.5	M5×10	ABS, PE
7	8×12	74.5	103.5	90.5	26	12.5	6.5	M5×10	ABS, PE
8	8×12	82.5	111.5	98.5	26	12.5	6.5	M5×10	ABS, PE
10	8×12	98.5	127.5	114.5	26	12.5	6.5	M5×10	ABS, PE
12	8×12	114.5	143.5	130.5	26	12.5	6.5	M5×10	ABS, PE

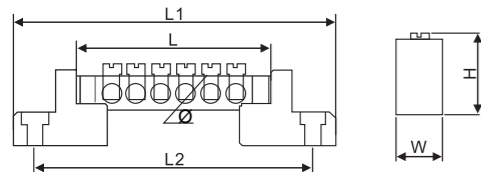

Электрические аксессуары

Клеммная колодка

HC-005

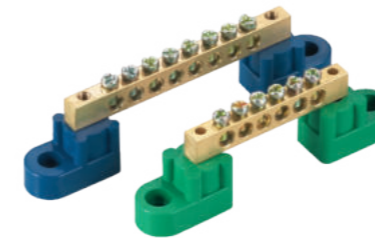

ПА, Полиамид марки 66,94-2. Замедлитель воспламенения. Рабочая температура: от -30°C до +110°C.
АБС-пластик с хорошей защитой от ударов и воздействия химических веществ. Рабочая температура: от -20 до +70°C.
РЕ, полипропилен, замедление воспламенения, низкая прозрачность, низкая жесткость, хорошая стойкость к ударам. Рабочая температура: от -30°C до +110°C.
Латунь. Винт — оцинкованная сталь.
Напряжение: 250-450 В.
Цвет: в соответствии с изображением образца или по индивидуальному заказу.

Кол-во конт.	Спец. Wxh	мм						Винт	Пластик. вставка
		L	L1	L2	H	W	Ø		
8	6×9	60	90	35	43	12	5.2	M4×7	ПА, ABS
10	6×9	73	90	35	43	12	5.2	M4×7	ПА, ABS
12	6×9	86	90	35	43	12	5.2	M4×7	ПА, ABS
14	6×9	99	90	35	43	12	5.2	M4×7	ПА, ABS
8	8×12	71	90	35	46	12	6.5	M5×10	ПА, ABS
10	8×12	87	90	35	46	12	6.5	M5×10	ПА, ABS
12	8×12	103	103	35	46	12	6.5	M5×10	ПА, ABS
14	8×12	119	119	35	46	12	6.5	M5×10	ПА, ABS

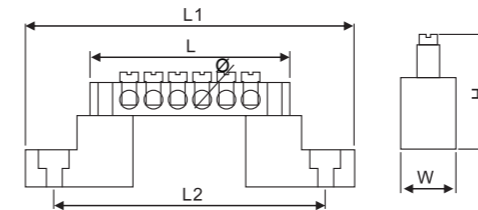

HC-006

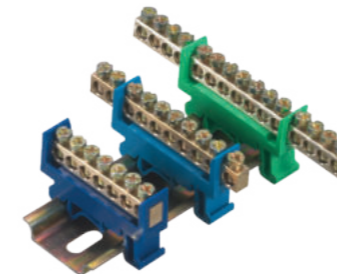

ПА, Полиамид марки 66,94-2. Замедлитель воспламенения. Рабочая температура: от -30°C до +110°C.
АБС-пластик с хорошей защитой от ударов и воздействия химических веществ. Рабочая температура: от -20°C до +70°C.
РЕ, полипропилен, замедление воспламенения, низкая прозрачность, низкая жесткость, хорошая стойкость к ударам. Рабочая температура: от -30°C до +110°C.
Латунь. Винт — оцинкованная сталь.
Напряжение: 250-450 В.
Цвет: в соответствии с изображением образца или по индивидуальному заказу.

Кол-во конт.	Спец. Wxh	мм						Винт	Пластик. вставка
		L	L1	L2	H	W	Ø		
7	6×9	51	51	35	32	12	5.3	M5×8	ПА
10	6×9	72	72	35	32	12	5.3	M5×8	ПА
12	6×9	85	85	35	32	12	5.3	M5×8	ПА
15	6×9	104.5	104.5	35	32	12	5.3	M5×8	ПА

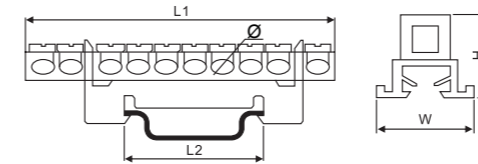

Электрические аксессуары Клеммная колодка

HC-007

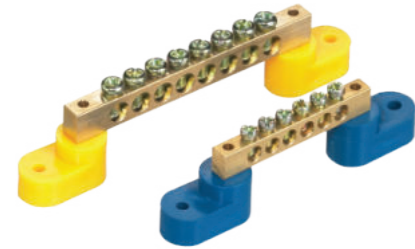

ПА, Полиамид марки 66,94-2. Замедлитель воспламенения. Рабочая температура: от -30°C до +110°C.

ABS с хорошей защитой от ударов и воздействия химических веществ. Рабочая температура: от -20°C до +70°C.

PE, полипропилен, замедление воспламенения, низкая прозрачность, низкая жесткость, хорошая стойкость к ударам. Рабочая температура: от -30°C до +110°C. Латунь. Винт — оцинкованная сталь.

Напряжение: 250-450 В.

Цвет: в соответствии с изображением образца или по индивидуальному заказу.

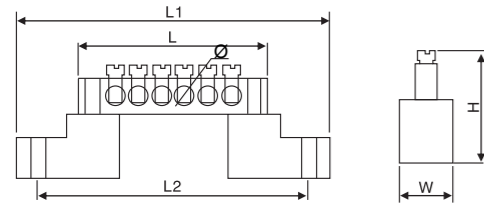

Кол-во конт.	Спец. Wxh	мм						Винт	Пластик. вставка
		L	L1	L2	H	W	Ø		
6	6×9	53.5	88.5	76.5	27.5	15	5	M4×7	ABS, PE
7	6×9	60	95	83	27.5	15	5	M4×7	ABS, PE
8	6×9	66.5	101.5	89.5	27.5	15	5	M4×7	ABS, PE
10	6×9	79.5	114.5	102.5	27.5	15	5	M4×7	ABS, PE
12	6×9	92.5	127.5	115.5	27.5	15	5	M4×7	ABS, PE
6	8×12	66.5	99.5	87.5	31	15	6.5	M5×10	ABS, PE
7	8×12	74.5	107.5	95.5	31	15	6.5	M5×10	ABS, PE
8	8×12	82.5	115.5	103.5	31	15	6.5	M5×10	ABS, PE
10	8×12	98.5	131.5	119.5	31	15	6.5	M5×10	ABS, PE
12	8×12	114.5	147.5	135.5	31	15	6.5	M5×10	ABS, PE

HC-008

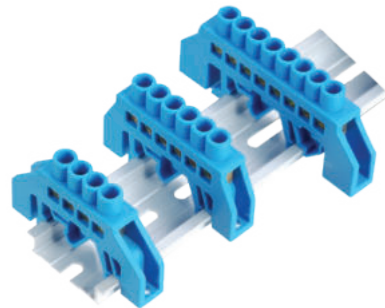

ПА, Полиамид марки 66,94-2. Замедлитель воспламенения. Рабочая температура: от -30°C до +110°C.

ABS с хорошей защитой от ударов и воздействия химических веществ. Рабочая температура: от -20°C до +70°C.

PE, полипропилен, замедление воспламенения, низкая прозрачность, низкая жесткость, хорошая стойкость к ударам. Рабочая температура: от -30°C до +110°C. Латунь. Винт — оцинкованная сталь.

Напряжение: 250-450 В.

Цвет: в соответствии с изображением образца или по индивидуальному заказу.

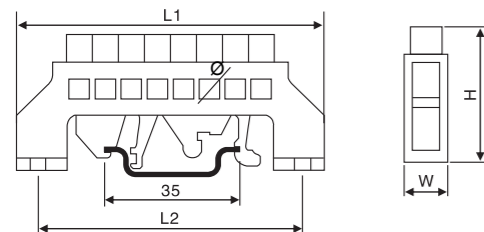

Кол-во конт.	Спец. Wxh	мм						Винт	Пластик. вставка
		L	L1	L2	H	W	Ø		
4	6×9	27	57	48	35	11	5	M4×7	PA
6	6×9	40	57	48	35	11	5	M4×7	PA
8	6×9	53	78	66	35	11	5	M4×7	PA
10	6×9	66	89	77	35	11	5	M4×7	PA
12	6×9	79	102	90	35	11	5	M4×7	PA

Электрические аксессуары Клеммная колодка

HC-009

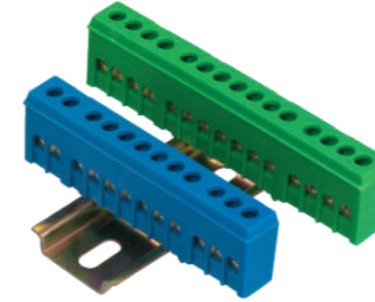

ПА, Полиамид марки 66,94-2. Замедлитель воспламенения. Рабочая температура: от -30°C до +110°C.

ABS с хорошей защитой от ударов и воздействия химических веществ. Рабочая температура: от -20°C до +70°C.

PE, полипропилен, замедление воспламенения, низкая прозрачность, низкая жесткость, хорошая стойкость к ударам. Рабочая температура: от -30°C до +110°C. Латунь. Винт — оцинкованная сталь.

Напряжение: 250-450 В.

Цвет: в соответствии с изображением образца или по индивидуальному заказу.

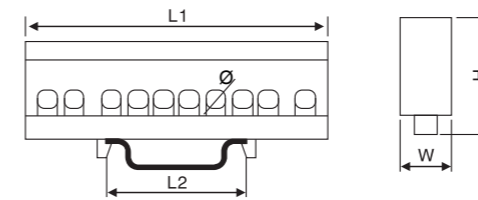

Кол-во конт.	Спец. Wxh	мм						Винт	Пластик. вставка
		L	L1	L2	H	W	Ø		
7	6×9	51	55	35	32	14	5.3	M5×8	PA
10	6×9	72	76	35	32	14	5.3	M5×8	PA
12	6×9	85	89	35	32	14	5.3	M5×8	PA
15	6×9	104.5	108.5	35	32	14	5.3	M5×8	PA

HC-010

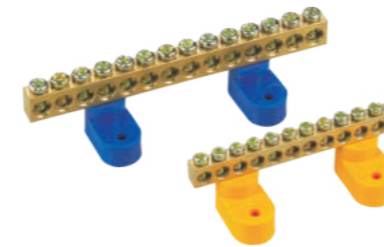

ПА, Полиамид марки 66,94-2. Замедлитель воспламенения. Рабочая температура: от -30°C до +110°C.

ABS с хорошей защитой от ударов и воздействия химических веществ. Рабочая температура: от -20°C до +70°C.

PE, полипропилен, замедление воспламенения, низкая прозрачность, низкая жесткость, хорошая стойкость к ударам. Рабочая температура: от -30°C до +110°C. Латунь. Винт — оцинкованная сталь.

Напряжение: 250-450 В.

Цвет: в соответствии с изображением образца или по индивидуальному заказу.

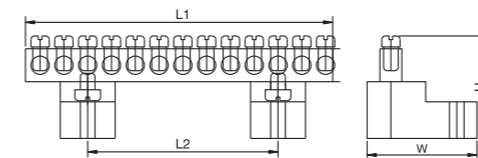

Кол-во конт.	Спец. Wxh	мм						Винт	Пластик. вставка
		L	L1	L2	H	W	Ø		
6	6×9	42	42	19.5	28	30	5.3	M4×8	ABS, PE
8	6×9	55	55	19.5	28	30	5.3	M4×8	ABS, PE
10	6×9	68	68	32.5	28	30	5.3	M4×8	ABS, PE
12	6×9	71	71	32.5	28	30	5.3	M4×8	ABS, PE
14	6×9	84	84	32.5	28	30	5.3	M4×8	ABS, PE
6	8×12	46	46	22.5	32	30	6	M5×9	ABS, PE
8	8×12	61	61	22.5	32	30	6	M5×9	ABS, PE
10	8×12	76	76	37.5	32	30	6	M5×9	ABS, PE
12	8×12	91	91	37.5	32	30	6	M5×9	ABS, PE
14	8×12	106	106	37.5	32	30	6	M5×9	ABS, PE

Электрические аксессуары

Клеммная колодка

HC-0012



ПА, Полиамид марки 66,94-2. Замедлитель воспламенения. Рабочая температура: от -30°C до +110°C.
 ABS с хорошей защитой от ударов и воздействия химических веществ. Рабочая температура: от -20°C до +70°C.
 PE, полипропилен, замедление воспламенения, низкая прозрачность, низкая жесткость, хорошая стойкость к ударам. Рабочая температура: от -30°C до +110°C.
 Латунь. Винт — оцинкованная сталь.
 Напряжение: 250-450 В.
 Цвет: в соответствии с изображением образца или по индивидуальному заказу.

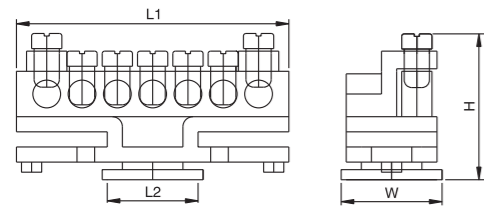

Кол-во конт.	Спец.	L	L1	L2	H	W	Ø	Винт	Пластик. вставка
	Wxh								
7	6 × 9	54	54	20	30	20	5.3	M5 × 8	

HC-013



ПА, Полиамид марки 66,94-2. Замедлитель воспламенения. Рабочая температура: от -30°C до +110°C.
 ABS с хорошей защитой от ударов и воздействия химических веществ. Рабочая температура: от -20°C до +70°C.
 PE, полипропилен, замедление воспламенения, низкая прозрачность, низкая жесткость, хорошая стойкость к ударам. Рабочая температура: от -30°C до +110°C.
 Латунь. Винт — оцинкованная сталь.
 Напряжение: 250-450 В.
 Цвет: в соответствии с изображением образца или по индивидуальному заказу.

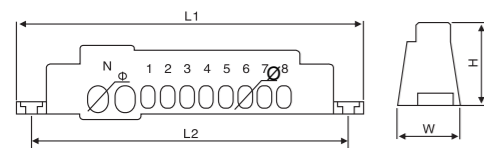

Кол-во конт.	Спец.	L	L1	L2	H	W	Ø	Винт	Пластик. вставка
	Wxh								
4	1.2		90	78	30	22	6(2 × 8)		РА
6	1.2		105	93	30	22	6(2 × 8)		РА
8	1.2		120	108	30	22	6(2 × 8)		РА
10	1.2		135	123	30	22	6(2 × 8)		РА
12	1.2		150	139	30	22	6(2 × 8)		РА

Электрические аксессуары

Клеммная колодка

HC-014



ПА, Полиамид марки 66,94-2. Замедлитель воспламенения. Рабочая температура: от -30°C до +110°C.
 ABS с хорошей защитой от ударов и воздействия химических веществ. Рабочая температура: от -20°C до +70°C.
 PE, полипропилен, замедление воспламенения, низкая прозрачность, низкая жесткость, хорошая стойкость к ударам. Рабочая температура: от -30°C до +110°C.
 Латунь. — оцинкованная сталь.
 Напряжение: 250-450 В.
 Цвет: в соответствии с изображением образца или по индивидуальному заказу.

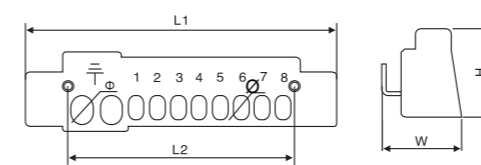

Кол-во конт.	Спец.	L	L1	L2	H	W	Ø	Винт	Пластик. вставка
	Wxh								
6	1.2		81	51	33	29	6(2 × 8)		РА
8	1.2		96	66	33	29	6(2 × 8)		РА
10	1.2		111	81	33	29	6(2 × 8)		РА
12	1.2		126	96	33	29	6(2 × 8)		РА
14	1.2		141	111	33	29	6(2 × 8)		РА

HC-016

ПА, Полиамид марки 66,94-2. Замедлитель воспламенения. Рабочая температура: от -30°C до +110°C..
 Латунь. Винт — оцинкованная сталь. Напряжение: 250-450 В.
 Цвет: в соответствии с изображением образца или по индивидуальному заказу.

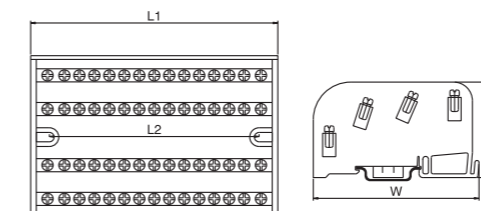

№	Спец.	Ном. ток (А)	Ном. напр. (В)	L1	L2	H	W	Макс. сечение (мм²)	Кол-во отверст.	Пласт. вставка
	Wxh									
207	6.5 × 12	125	500	67	48	50	45	35	2 × 7	РА
211	6.5 × 12	125	500	100	86	50	45	35	2 × 11	РА
215	6.5 × 12	125	500	134	118	50	45	35	2 × 15	РА
407	6.5 × 12	125	500	67	48	50	90	35	4 × 7	РА
411	6.5 × 12	125	500	100	86	50	90	35	4 × 11	РА
415	6.5 × 12	125	500	134	118	50	90	35	4 × 15	РА
413	8 × 17	160	500	180	168	73	138	50	4 × 13	РА

Электрические аксессуары Клеммная колодка

HC-017



ПА, Полиамид марки 66,94-2. Замедлитель воспламенения. Рабочая температура: от -30°C до +110°C.

Латунь. Винт — оцинкованная сталь.

Напряжение: 250-450 В.

Цвет: в соответствии с изображением образца или по индивидуальному заказу.

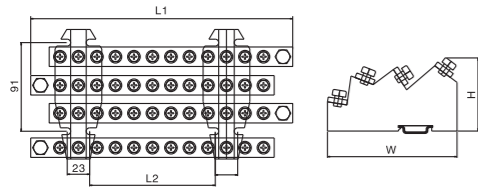

№	Спец. Wxh	Ном. ток (А)	Ном. напр. (В)	мм				Макс. сечение (мм ²)	Кол-во отверст.	Пласт. вставка
				L1	L2	H	W			
420	4 × 15	200	500	280	128	115	190	75	4 × 11	РА
425	5 × 20	250	500	280	128	115	190	100	4 × 11	РА
440	6 × 25	400	500	280	128	115	190	185	4 × 10	РА

HC-018



ПА, Полиамид марки 66,94-2. Замедлитель воспламенения. Рабочая температура: от -30°C до +110°C.

Латунь. Винт — оцинкованная сталь.

Напряжение: 250-450 В.

Цвет: в соответствии с изображением образца или по индивидуальному заказу.

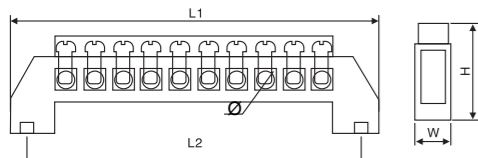

Кол-во конт.	Спец. Wxh	L	L1	L2	H	W	Ø	Винт	Пластик. вставка
4	1.2		90	78	30	22	6(2 × 8)		РА
6	1.2		105	93	30	22	6(2 × 8)		РА
8	1.2		120	108	30	22	6(2 × 8)		РА
10	1.2		135	123	30	22	6(2 × 8)		РА
12	1.2		150	139	30	22	6(2 × 8)		РА

Электрические аксессуары Клеммная колодка

HC-022

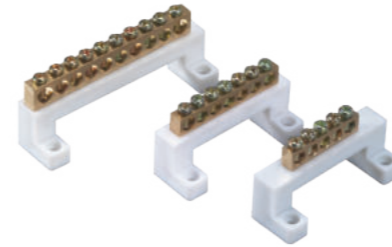

ПА, Полиамид марки 66,94-2. Замедлитель воспламенения. Рабочая температура: от -30°C до +110°C.

Латунь. Винт — оцинкованная сталь.

Напряжение: 250-450 В.

Цвет: в соответствии с изображением образца или по индивидуальному заказу.

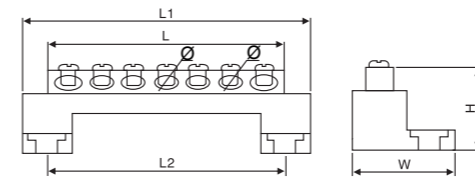

Кол-во конт.	Спец. Wxh	L	L1	L2	H	W	Ø	Винт	Пластик. вставка
5	7 × 11	42.5	73	60	37	26	6.5(2 × 7)	M5 × 8	ABS, PE
7	7 × 11	58.5	73	60	37	26	6.5(2 × 7)	M5 × 8	ABS, PE
10	7 × 11	82.5	103	90	37	26	6.5(2 × 7)	M5 × 8	ABS, PE
5	8 × 13	52	73	60	40	26	7(2 × 9)	M5 × 10	ABS, PE
7	8 × 13	70	73	60	40	26	7(2 × 9)	M5 × 10	ABS, PE
10	8 × 13	97	103	90	40	26	7(2 × 9)	M5 × 10	ABS, PE

HC-023



ПА, Полиамид марки 66,94-2. Замедлитель воспламенения. Рабочая температура: от -30°C до +110°C.

Латунь. Винт — оцинкованная сталь.

Напряжение: 250-450 В.

Цвет: в соответствии с изображением образца или по индивидуальному заказу.

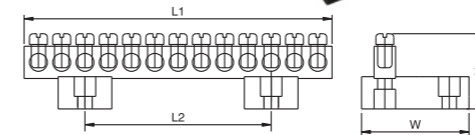

Кол-во конт.	Спец. Wxh	L	L1	L2	H	W	Ø	Винт	Пластик. вставка
6	6 × 9	42	42	20	21	30	5.3	M4 × 8	ABS, PE
8	6 × 9	55	55	20	21	30	5.3	M4 × 8	ABS, PE
10	6 × 9	68	68	33	21	30	5.3	M4 × 8	ABS, PE
12	6 × 9	71	71	33	21	30	5.3	M4 × 8	ABS, PE
14	6 × 9	84	84	33	21	30	5.3	M4 × 8	ABS, PE

HC-026

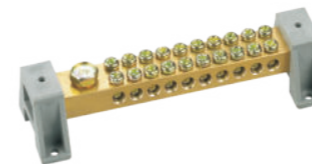

АБС-пластик, стойкий к ударам и воздействию химических веществ. Рабочая температура: от -20°C до +70°C.

Латунь. Винт — оцинкованная сталь.

Напряжение: 250-450 В.

Цвет: в соответствии с изображением образца или по индивидуальному заказу.

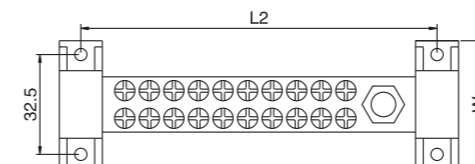

Кол-во конт.	Спец. Wxh	L	L1	L2	H	W	Ø	Винт	Пластик. вставка
1+4	9 × 18	64	82	68	29	42	5.3	M5 × 8	ABS, PE
1+6	9 × 18	80	98	84	29	42	5.3	M5 × 8	ABS, PE
1+8	9 × 18	96	114	100	29	42	5.3	M5 × 8	ABS, PE
1+4	12 × 18	64	82	68	29	42	5.3	M5 × 8	ABS, PE
1+6	12 × 18	80	98	84	29	42	5.3	M5 × 8	ABS, PE
1+8	12 × 18	96	114	100	29	42	5.3	M5 × 8	ABS, PE

Электрические аксессуары

Клеммная колодка

HC-024



АБС-пластик, стойкий к ударам и воздействию химических веществ. Рабочая температура: от -20°C до +70°C.

Латунь. Винт — оцинкованная сталь.

Напряжение: 250-450 В.

Цвет: в соответствии с изображением образца или по индивидуальному заказу.

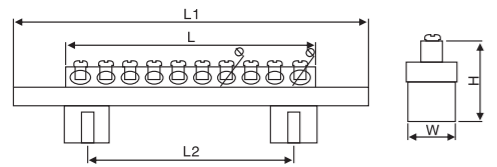

Кол-во конт.	Спец. Wxh	мм						Винт	Пластик. вставка
		L	L1	L2	H	W	Ø		
5	7×11	42.5	120	70	35	16	6.5(2×7)	M5×8	ABS, PE
7	7×11	58.5	120	70	35	16	6.5(2×7)	M5×8	ABS, PE
10	7×11	82.5	120	70	35	16	6.5(2×7)	M5×8	ABS, PE

HC-025



АБС-пластик, стойкий к ударам и воздействию химических веществ. Рабочая температура: от -20°C до 70°C.

Латунь. Винт — оцинкованная сталь.

Напряжение: 250-450В.

Цвет: в соответствии с изображением образца или по индивидуальному заказу.

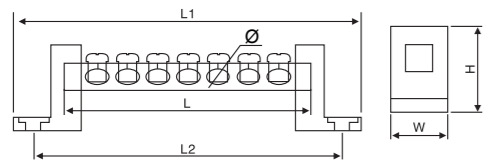

Кол-во конт.	Спец. Wxh	мм						Винт	Пластик. вставка
		L	L1	L2	H	W	Ø		
3	7×10	33	59.5	49.5	35	15	6.5	M5×9	ABS
4	7×10	41	67.5	57.5	35	15	6.5	M5×9	ABS
5	7×10	49	75.5	65.5	35	15	6.5	M5×9	ABS
6	7×10	57	83.5	73.5	35	15	6.5	M5×9	ABS
7	7×10	65	91.5	81.5	35	15	6.5	M5×9	ABS
8	7×10	73	99.5	89.5	35	15	6.5	M5×9	ABS
10	7×10	90	116.5	106.5	35	15	6.5	M5×9	ABS
12	7×10	106	132.5	122.5	35	15	6.5	M5×9	ABS
15	7×10	130	156.5	146.5	35	15	6.5	M5×9	ABS
3	9×15	46	68	58	35	15	9(2×10)	M5×12	ABS
5	9×15	68	90	80	35	15	9(2×10)	M5×12	ABS
7	9×15	90	112	102	35	15	9(2×10)	M5×12	ABS
8	9×15	101	123	113	35	15	9(2×10)	M5×12	ABS
10	9×15	123	145	135	35	15	9(2×10)	M5×12	ABS
12	9×15	145	167	157	35	15	9(2×10)	M5×12	ABS
15	9×15	178	200	190	35	15	9(2×10)	M5×12	ABS

Электрические аксессуары

Однополюсная распределительная коробка UKK

UKK

Общая информация и внешний ид

Материал: PA нейлон.

Класс огнестойкости: UL94V0

Металлические компоненты: латунь

Прозрачная крышка позволяет визуально оценить соединение.

Модель	Ток (А)	Напряжение (В)	Проводники с зажимами Starfix, сечение (мм²)	Кол-во отверстий (шт)	Размеры (Д×Ш×В) (мм)
UKK-80	80А	690А IEC	6 - 16 / 2.5 - 6 / 2.5 - 16	×1 / ×4 / ×2	31×70×45.5
UKK-125	125А	690А IEC	10 - 35 / 2.5 - 16	×1 / ×7	30×76.5×45.5
UKK-160	160А	690А IEC	10 - 70 / 2.5 - 16	×1 / ×7	30×76.5×45.5
UKK-250	250А	690А IEC	35 - 120 / 6 - 35 / 2.5 - 16 / 2.5 - 10	×1 / ×2 / ×5 / ×4	49×95×49
UKK-400	400А	690А IEC	95 - 185 / 6 - 35 / 2.5 - 16 / 2.5 - 10	×1 / ×2 / ×5 / ×4	49×95×49
UKK500	500А	690А IEC	4×15.5×0.8 to 8×24 / 6 - 35 / 2.5 - 16 / 2.5 - 10	×1 / ×2 / ×5 / ×4	49×95×49

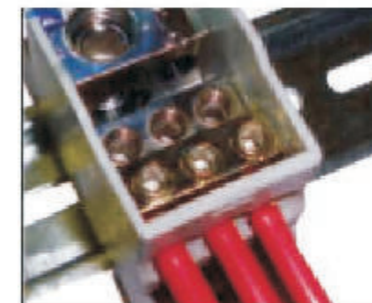
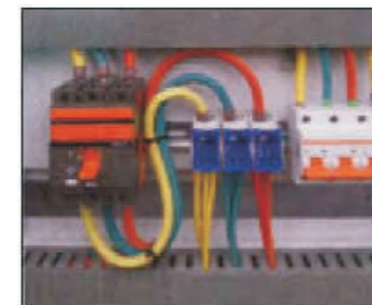

UKK-80



UKK-125



UKK-160



UKK-250



UKK-400



UKK-500